

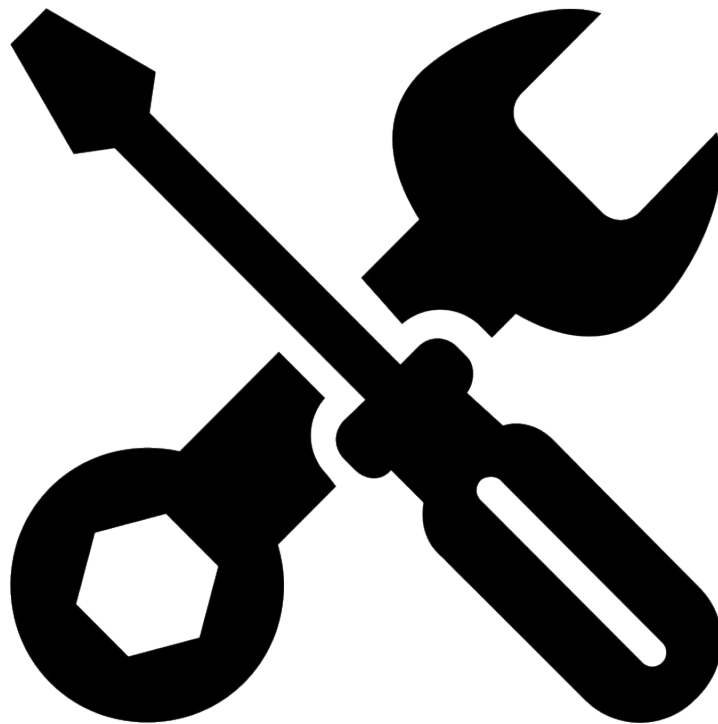

BRASCH
ENVIRONMENTAL TECHNOLOGIES

Troubleshooting Guide

Generation 2



Brasch Environmental Technologies, LLC
140 Long Road, Suite 101
Chesterfield, Missouri 63005
314-291-0440
www.braschenvtech.com

Table of Contents

Standalone Detectors.....	4
Introduction.....	4
Error Codes.....	4
Transmit Timeout – 9501.....	4
Failed Sensor – 960x.....	5
Cannot Run Self-Test – 9802.....	6
Sensor Fault – 9994.....	7
End-of-Life – 9995.....	7
Module Fault – 9996.....	7
Invalid Calibration Values – 9997.....	7
No Active Zones – 9998.....	8
No Active Sensors – 9999.....	8
Calibration Expired – rCAL.....	8
Miscellaneous.....	8
Power Loss – Base Station.....	8
Power Loss – Sensor Boards.....	9
Low Alert Relay Operates on a Schedule.....	10
Equipment Runs Constantly.....	10
Equipment Activates at the Wrong Time.....	10
Equipment Does Not Activate.....	10
Low Alert Disengages with High Alert.....	11
Proportional Output Provides the Wrong Signal.....	11
Proportional Output Provides a Constant Signal.....	11
Gas Readings are Unsatisfactory.....	12
Control Panel.....	13
Introduction.....	13
Error Messages.....	13
Relay # – Manual Override Active.....	13
Sensor # Communication Loss.....	13
Sensor # – Calibration Expired.....	16
Sensor # Sensor Fault.....	16
Sensor # End of Life – Please Replace.....	16
Sensor # Module Fault.....	16
Sensor # Calibration Invalid.....	16
Relay Board # Communication Loss.....	17
SD Card Error – Insert SD Card.....	19
SD Card Error – Replace SD Card.....	19
Miscellaneous.....	19
Power Loss – Control Panel/Expansion Packs.....	19
Power Loss – Sensors.....	20
Black Display with Power On.....	20
Equipment Runs Constantly.....	21
Equipment Activates at the Wrong Time.....	21

Equipment Does Not Activate.....	21
Relays Deactivate when Other Relays Activate.....	22
Proportional Output Provides the Wrong Signal.....	22
Proportional Output Provides a Constant Signal.....	22
Gas Readings are Unsatisfactory.....	23
Replacement Parts.....	24
Replacing Sensor Boards of Different Revisions.....	25
Rev A-G.....	25
Rev H.....	25
Appendix.....	26
Control Board Layout.....	26
Legend.....	26
Acceptable Measurements.....	26
Sensor Board Layout.....	27
Legend.....	27
Acceptable Measurements.....	27
Interface Board Layout.....	28
Legend.....	28
Acceptable Measurements.....	28
Relay Board Layout.....	29
Legend.....	29
Acceptable Measurements.....	29
Addressing.....	30
Sensor Board.....	30
Relay Board.....	32
Troubleshooting Flowchart.....	33
Acceptable Measurements Reference.....	34
Limited Warranty.....	35
Warranty Statement.....	35
Service and Repair Procedures.....	35

Standalone Detectors

Introduction

This section covers the troubleshooting procedures for all GSE Generation 2 Standalone Detectors. These consist of Brasch models beginning with the prefix “GSE2”. Each detector base station is equipped with a four-by-seven segment display on which any error codes appearing during self-diagnostics will appear. Not all problems will result in an error code. See the appendix for board layouts, test points, and acceptable measurements.

Error Codes

The Brasch GSE Generation 2 Gas Detector is programmed to display error codes to indicate a problem condition with the unit.

Code	Description
9501	Transmit Timeout
9601	Failed Communication with Sensor 1
9602	Failed Communication with Sensor 2
9603	Failed Communication with Sensor 3
9604	Failed Communication with Sensor 4
9802	Cannot Run Self-Test
9995	Sensor End-of-Life Signal
9996	Sensor Not Installed
9997	Invalid Calibration Values
9998	No Active Zones
9999	No Active Sensors
rCAL	Calibration Expired

Transmit Timeout – 9501

Problem: The control board is not able to send a signal on the communication line.

Checks: None

Solution: Replace the control board.

Failed Sensor – 960x

Problem: The control board cannot establish communication with one or more of the sensor boards.

Checks:

1. Power
 - a) Green power LEDs illuminate
 - b) Sensor boards have between 20 and 28 VAC for incoming power
 - c) Sensor board fuses F1 should have continuity
 - d) Voltage between TP4 and TP3 on the sensor board should be 5 VDC
 - e) Voltage between TP2 and TP3 on the control board should be 15 VDC
2. Wiring
 - a) Wiring connections are terminated properly between the control board and sensor board(s)
 - b) End-of-line termination resistor is enabled on remote transmitters
3. Other
 - a) Verify the address on SW1 matches the sensor number on the front sticker
 - b) Connect remote sensors directly to the control board to eliminate the possibility of wiring issues
 - c) Check resistance between TP4 and TP3 on the sensor board for shorts
 - d) Check resistance between TP2 and TP3 on the control board for shorts

Solutions:

1. Power
 - a) Incoming power to the sensor board should be > 20 VAC and < 28 VAC. It is rated for 24 VAC ± 3 VAC but can withstand slightly higher or lower voltages. Too low a voltage and the sensor will not power or communicate. Too high a voltage and the board may suffer damage. As power comes from the control board, improper power at the sensor board indicates the control/interface boards may need to be replaced.
 - b) In the event of overload, the sensor board fuse is designed to blow and protect the circuitry. A spare F1 fuse is included with each detector for this case.
 - c) Higher/lower voltage on the test points indicates damage to the regulators. If this is the case, the control/sensor board must be replaced.

2. Wiring

- a) If the communication wires are flipped or not connected, communication will fail. Communication wires must be securely connected to the correct terminals for communication to work.
- b) Any voltage that gets on the communication wires will interrupt communication. Likewise, grounding the communication wires will also interrupt communication. Provided the board is not damaged, isolating the communication wires will resolve the issue.
- c) A termination resistor is not always necessary, but it can help to prevent signal reflections from interrupting communication.

3. Other

- a) Multiple sensor boards with the same address will cause communication failure on all such boards. Ensure each sensor board has a unique address at SW1. Ensure the control board has these addresses set as active on SW3.
- b) If any fuses are blown, replace the fuse.
- c) If resistance at the 5 V test point is $< 500 \Omega$, communication will be compromised. This indicates a short on the 5 V rail which most often occurs through the RS485. If the short is present on the sensor board, replace the sensor board. If the short is present on the control board, replace the control board.

Cannot Run Self-Test – 9802

Problem: The self-test sequence failed to run in its entirety.

Checks:

1. High Gas Concentrations
 - a) Restart the detector, allow it to finish its warm-up sequence, and verify that the gas readings on all sensors are below the Low Alert level.
2. Error Conditions
 - a) Restart the detector, allow it to finish its warm-up sequence, and verify that no error codes are present.

Solutions:

1. High Gas Concentrations

- a) If the gas concentration is above the Low Alert setpoint, the self-test will fail. Increase the ventilation and/or wait for the concentration to drop low enough before running the self-test.

2. Error Conditions

- a) If there is an error condition present, resolve the error. Then run the self-test. The most common errors that cause this condition are a missing sensor or a communication loss.

Sensor Fault – 9994

Problem: The sensing element is either open or shorted between two or more pins.

Checks: Check that the sensor is firmly connected to all sockets on the module.

Solutions: Press the sensor all the way into the module. If the problem persists, replace the sensor module.

End-of-Life – 9995

Problem: The sensor board clock has expired, indicating the sensor has reached the expected end of its useful lifetime.

Checks: Check the anticipated end-of-life date against the manufacturing date.

Solutions: Replace the sensor module.

Module Fault – 9996

Problem: The sensor board does not detect the presence of a sensor module.

Checks: Verify that there is a sensor module on the sensor board in the appropriate slot, and that the pins are properly aligned in the headers.

Solution: Align and press the sensor module firmly into the headers. If the pins are bent or broken, it may be necessary to replace the sensor module.

Invalid Calibration Values – 9997

Problem: Zero and span values are not saved in memory.

Checks: None

Solution: Perform a full calibration on the sensor module. If the calibration fails and the error persists, replace the sensor module.

No Active Zones – 9998

Problem: The sensors are not assigned to a zone.

Checks: None

Solution: Replace the control board.

No Active Sensors – 9999

Problem: No sensors are selected as active on SW3.

Checks: None

Solution: Set at least one active sensor on SW3 and restart the detector.

Calibration Expired – rCAL

Problem: The calibration on the sensor module has expired.

Checks: None

Solution: Calibrate or replace the sensor module.

Miscellaneous

Power Loss – Base Station

Problem: The main detector does not power ON.

Checks:

1. Power
 - a) Verify that the incoming voltage matches the input requirements
 - b) Check that all wires are secure in the correct terminals
 - c) Check that all harnesses are firmly connected
2. Switches
 - a) Ensure the power switch is in the ON position
 - b) Verify that any disconnect switches and circuit breakers are ON
3. Fuse
 - a) Check for continuity across the main power fuse (F1)

Solutions:

1. Power
 - a) Input voltage below the rated limit will be insufficient to run the detector. Correct the source and reapply power.
 - b) Input voltage above the rated limit will cause damage. Correct the source, then check the fuse – replacing if necessary. Reapply power to check for damage. The control board may need to be replaced.
 - c) Any wires/harnesses that are loose or disconnected should be fixed. Replace the wire/harness if necessary.
2. Switch
 - a) If any switches (disconnect, breaker, or detector) are OFF, make sure it is safe to apply power, then flip the appropriate switches ON.
3. Fuse
 - a) Blown fuses will measure OL. A spare main fuse is included with each detector. Replace the fuse and check for power.

Power Loss – Sensor Boards

Problem: One or more sensor boards do not power ON (but the control board does).

Checks:

1. Power
 - a) Verify the incoming voltage is ~33 VDC
 - b) Check that all wires are secure in the correct terminals
 - c) Check that all harnesses are firmly connected
2. Fuse
 - a) Check for continuity across the main fuse (F1)

Solutions:

1. Power
 - a) If the incoming voltage is too high or low, replace the control board.
 - b) Any wires/harnesses that are loose or disconnected should be fixed. Replace the wire/harness if necessary.
2. Fuse

- a) Blown fuses will measure OL. A spare F1 fuse is included with each detector. Replace the fuse and check for power.

Low Alert Relay Operates on a Schedule

Problem: The low alert relay closes for 15 minutes, then opens for 45 minutes each hour.

Check: Verify the firmware version of the control board.

Solution: Control boards with v 1.0 must be updated to eliminate the 15/45 mode.

Equipment Runs Constantly

Problem: Ventilation or warning equipment connected to one or more of the detector relays runs constantly.

Check: Verify the relay opens and closes with the self-test mode.

Solution: If the relay opens and closes during self-test, the manual override may need to be disengaged by pressing the appropriate button on the front cover of the detector. If the relay state does not change, replace the control board and/or interface board.

Equipment Activates at the Wrong Time

Problem: Ventilation or warning equipment does not activate when desired.

Check: Verify the equipment is connected to the appropriate relays and that the alert/delay settings are as desired for the Low Alert.

Solution: Move the equipment wiring to the correct relay terminals and adjust the alert/delay settings as needed. Restart the detector once any settings changes are made.

Equipment Does Not Activate

Problem: Ventilation or warning equipment does not activate at all.

Check:

1. Detector
 - a) Verify the equipment is connected to the appropriate relays
 - b) Check that sensors are configured to the correct zone on the control board (SW4)
 - c) Run the self-test to verify relay operation
 - d) Measure relay fuses to check for blown fuses
2. Ventilation/Warning Equipment

- a) Verify the equipment is wired properly
- b) Ensure the equipment has the proper input voltage

Solution:

1. Detector

- a) Equipment connected to the wrong relays or zones will not be activated by the detector. Fix wiring connections and/or change the settings on the control board to resolve the issue.
- b) If any relay fuses are blown, verify that the equipment is not drawing too much current through the fuses. Relay fuses are only rated for 5 A @ 125 VAC. External relays, motor starters, contactors, etc. may need to be installed.
- c) If the relay state never changes during the self-test mode and the relay fuse is intact, replace the control and/or interface board.

2. Ventilation/Warning Equipment

- a) Detector relays are dry contacts and do not provide control voltage. If equipment requires voltage, this must be properly supplied and routed through the relays.

Low Alert Disengages with High Alert

Problem: Equipment shuts down when gas levels continue to rise above the High Alert level.

Check: Verify the position of the fan speed jumpers (JP5 and JP10).

Solution: Move the jumpers to the upper two pins on both JP5 and JP10 to select 50/100 operation.

Proportional Output Provides the Wrong Signal

Problem: The proportional output provides the wrong signal.

Check: Verify the DIP switch positions on SW6 and SW7 match the desired setting.

Solution: Move the DIP switches on SW6 and SW7 to the desired setting.

Proportional Output Provides a Constant Signal

Problem: The proportional output provides a constant signal.

Check:

1. Settings

- a) Verify that SW6 and SW7 are set to the appropriate position

2. Power

- a) Verify that the sensor board has power
- b) Measure voltage/resistance between TP4 and TP3
- c) Measure voltage between TP1 or TP7 and TP3 while applying test gas

Solution:

1. Settings

- a) Move the DIP switches on SW6 and SW7 to the desired position

2. Power

- a) If the sensor board does not have power, the proportional output will not work. Troubleshoot the power loss and check again.
- b) If the sensor board has been damaged by shorting the 5 V to ground, the analog output will be constant. Replace the sensor board and ensure that no damage is being caused by the device connected to the proportional output prior to making any connections.
- c) If the voltage at TP1 or TP7 does not change, neither will the proportional output. Verify the test gas and sensor operation.
 - i. If the test gas is wrong, try again using the correct setup.
 - ii. If the sensor does not respond to gas, replace the sensor module.
- d) If the voltage at TP1 or TP7 does change but the proportional output does not, replace the sensor board.

Gas Readings are Unsatisfactory

Problem: The detector does not register the desired concentration of target gas.

Check: Examine the calibration date on each sensor.

Solution: Recalibrate any sensors or replace sensor modules as required.

Control Panel

Introduction

This section covers the troubleshooting procedures for the GDCP-Touch Multi-Zone Control Panel and associated products. These consist of Brasch models beginning with the prefix “GDCP”. Each control panel is equipped with a 7” touchscreen display on which any error messages appearing during self-diagnostics will appear. Not all problems will result in an error message. See the appendix for board layouts, test points, and acceptable measurements.

Error Messages

The GDCP-Touch is programmed to display error messages to indicate a problem condition with the unit. The bottom center of the *Home Screen* will scroll through each message present. When an error occurs, the alarm will chirp and a silence button will replace the calendar icon to allow a user to mute the alarm. Any associated Level 1 relays (if able) will activate during an error state.

Relay # – Manual Override Active

Problem: The relay is stuck in either the open or closed position due to a manual override being active.

Checks: None

Solution: Go to *Settings > Relay Settings > Relay #* and set the override to “None”.

Sensor # Communication Loss

Problem: The control panel cannot establish communication with one or more of the sensor boards.

Checks:

1. Power
 - a) Green power LEDs illuminate
 - b) Sensor boards have between 20 and 28 VAC for incoming power
 - c) Sensor board fuse F1 should have continuity
 - d) Voltage between TP4 and TP3 on the sensor board should be 5 VDC
 - e) Voltage between TP4 and TP3 on the relay board should be 5 VDC

2. Wiring

- a) Wiring connections are terminated properly between the relay board and sensor board(s)
- b) End-of-line termination resistor is switched ON at the final sensor board
- c) End-of-line termination resistor is switched ON at each relay board
- d) Bias resistors are in the appropriate positions on each relay board
- e) Wires are not flipped between system components (i.e., +/- 24 VAC, +/- COMM)

3. Other

- a) Verify the address on SW1 matches the sensor number on the front sticker
- b) Connect remote transmitters directly to the relay board to eliminate the possibility of wiring issues
- c) Check resistance between TP4 and TP3 on the sensor board for shorts
- d) Check resistance between TP4 and TP3 on the relay board for shorts
- e) Check resistance between +COMM and -COMM
- f) Check resistance from +COMM to COM and from -COMM to COM

Solutions:

1. Power

- a) Incoming power to the sensor board should be > 20 VAC and < 28 VAC. It is rated for $24 \text{ VAC} \pm 3 \text{ VAC}$ but can withstand slightly higher or lower voltages. Too low a voltage and the transmitter will not power or communicate. Too high a voltage and the board may suffer damage.
- b) In the event of overload, the sensor board fuses are designed to blow and protect the circuitry. A spare F1 fuse is included with each control panel for this case.
- c) Higher/lower voltage on the test points indicates damage to the regulators. If this is the case, the relay/sensor board must be replaced.

2. Wiring

- a) If the communication wires are flipped or not connected, communication will fail. Communication wires must be securely connected to the correct terminals for communication to work.
- b) Any voltage that gets on the communication wires will interrupt communication. Likewise, grounding the communication wires will also interrupt communication.

Provided the board is not damaged, isolating the communication wires will resolve the issue.

- c) A termination resistor is not always necessary, but it can help to prevent signal reflections from interrupting communication.
- d) Bias resistors in the wrong position may prevent communication. Set all bias resistors ON for the relay board inside the control panel and OFF for the incoming communication side of any expansion packs.
- e) Flipped power wires will cause system components to be out-of-phase and can interrupt communication. Flipped communication wires will prevent communication from proceeding beyond the location where the flip occurs. In either case, ensure that each wire is connected to the same terminals throughout the system.

3. Other

- a) Multiple sensors with the same address will cause communication failure on both sensors. Ensure each sensor board has a unique address at SW1 and that SW2 is set for the appropriate number of sensor modules on the board. If there are two sensors on one sensor board, the next sensor board should skip one address. Ensure the control panel has these addresses set as active in the *Sensor Map*.
- b) If any fuses are blown, replace the fuse.
- c) If resistance at the 5 V test point is $< 500 \Omega$, communication will be compromised. This indicates a short on the 5 V rail which most often occurs through the RS485. If the short is present on the sensor board, replace the sensor board. If the short is present on the relay board, replace the relay board.
- d) If resistance is less than 60Ω , evaluate the wiring to make sure that the communication wires are not crossed or making contact with each other. If resistance is approximately 120Ω or greater, make sure that termination resistors are enabled at either end of the communication line.
- e) When measured as part of the system, resistance should be $> 500 \Omega$ between \pm COMM and COM. Both +COMM to COM and -COMM to COM should be close to the same value. If the resistance is too low, or if the values vary more than 5%, break the system down into smaller segments to isolate the source of the errant measurements.
- f) When measured as a single board, resistance should be $> 50 \text{ k}\Omega$ between \pm COMM and COM. Both +COMM to COM and -COMM to COM should be close to the same value. If the resistance is too low, or if the values vary more than 5%, replace the board.

Sensor # – Calibration Expired

Problem: A sensor module's internal timer has indicated that its expected calibration period has expired.

Check: Verify the manufacturing and calibration expiration dates.

Solution: Replace or recalibrate the sensor module. This error may be silenced for one month at a time by pressing the "Clear" button on the *Home Screen* if a calibration cannot (or does not need to) be performed. If the message does not clear, the sensor module must be recalibrated or replaced.

Sensor # Sensor Fault

Problem: The sensing element is either open or shorted between two or more pins.

Checks: Check that the sensor is firmly connected to all sockets on the module.

Solutions: Press the sensor all the way into the module. If the problem persists, replace the sensor module.

Sensor # End of Life – Please Replace

Problem: The sensor module clock has expired, indicating the sensor has reached the expected end of its useful lifetime.

Checks: None

Solutions: Replace the sensor module if it has reached end-of-life.

Sensor # Module Fault

Problem: The sensor board does not detect the presence of a sensor module.

Checks: Verify that there is a sensor module on the sensor board and that it is properly aligned with the headers. Conversely, ensure that SW2 reflects the desired number of sensor modules to be present on the sensor board.

Solution: Insert a sensor module into the headers. Pay attention to the circular outline on the silkscreen to indicate proper alignment. If any of the pins are bent or broken, it may be necessary to replace the sensor module.

Sensor # Calibration Invalid

Problem: Zero and/or span values are not saved in memory.

Checks: None

Solution: Perform a full calibration on the sensor module. If the calibration fails and the error persists, replace the sensor module.

Relay Board # Communication Loss

Problem: The control panel cannot establish communication with one or more of the relay boards.

Checks:

1. Power
 - a) Power switch is in the ON position
 - b) Green power LED illuminates
 - c) Amber transmit LED illuminates
 - d) Relay boards have between 18 and 28 VAC for incoming power
 - e) Relay board fuse F1 should have continuity
 - f) Voltage between TP4 and TP1 on the sensor board should be 33 VDC
 - g) Voltage between TP4 and TP2 on the relay board should be 5 VDC
 - h) Voltage between TP4 and TP3 on the relay board should be 5 VDC
2. Wiring
 - a) Wiring connections are terminated properly at the relay board
 - b) End-of-line termination resistor is switched ON
 - c) Bias resistors are in the appropriate positions
 - d) Wires are not flipped between system components (i.e., +/- 24 VAC, +/- COMM)
3. Other
 - a) Verify the address on SW1 matches the designation at the control panel
 - b) Connect expansion packs directly to the control panel to eliminate the possibility of wiring issues
 - c) Check resistance between TP4 and TP3 on the relay board for shorts

Solutions:

1. Power
 - a) With the power switch OFF, no communication will occur at or through the relay board. Make sure this switch is in the ON position at all times during operation.

- b) Incoming power to the relay board must be > 20 VAC and < 28 VAC. It is rated for 24 VAC ± 3 VAC but can withstand slightly higher or lower voltages. Too low a voltage and the relay board will not power or communicate. Too high a voltage and the board may suffer damage.
- c) In the event of overload, the relay board fuse is designed to blow and protect the circuitry. A spare F1 fuse is included with each control panel for this case.
- d) Higher/lower voltage on the test points indicates damage to the regulators. If this is the case, the relay board must be replaced.

2. Wiring

- a) If the wires are flipped or not connected, communication will fail. Communication wires must be securely connected to the correct terminals for communication to work. Incoming communication should land at TS7 with outgoing communication at TS8 or TS11.
- b) Any voltage that gets on the communication wires will interrupt communication. Likewise, grounding the communication wires will also interrupt communication. Provided the board is not damaged, isolating the communication wires will resolve the issue.
- c) A termination resistor is not always necessary, but it can help to prevent signal reflections from interrupting communication.
- d) Bias resistors in the wrong position may prevent communication. Set all bias resistors ON for the relay board inside the control panel and OFF for the incoming communication side of any expansion packs.
- e) Flipped power wires will cause system components to be out-of-phase and can interrupt communication. Flipped communication wires will prevent communication from proceeding beyond the location where the flip occurs. In either case, ensure that each wire is connected to the same terminals throughout the system.

3. Other

- a) Multiple relay boards with the same address will cause communication failure on both relay boards. Ensure each relay board has a unique address at SW1. Ensure the control panel has these addresses set as active in the *Relay Map*.
- b) If any fuses are blown, replace the fuse.
- c) If resistance at the 5 V test points is $< 500 \Omega$, communication will be compromised. This indicates a short on the 5 V rail which most often occurs through the RS485. If a short is present, replace the relay board.

SD Card Error – Insert SD Card

Problem: No microSD card is present.

Checks: None

Solution: Insert a microSD card into the slot on the back of the touchscreen assembly. If the error message does not clear, try a different microSD card. If the error message still does not clear, replace the touchscreen assembly.

SD Card Error – Replace SD Card

Problem: The control panel cannot write data to the microSD card.

Checks: None

Solution: Replace the microSD card to clear the error.

Miscellaneous

Power Loss – Control Panel/Expansion Packs

Problem: The relay board does not power ON.

Checks:

1. Power
 - a) Verify the incoming voltage is 18-28 VAC
 - b) Ensure the power switch is ON
 - b) Check that all wires are secure in the correct terminals
3. Fuse
 - a) Check for continuity across the main fuse (F1)

Solutions:

1. Power
 - a) If the incoming voltage is too high or low, replace the relay board.
 - b) Make sure the power switch is in the ON position at all times during operation.
 - c) Any wires that are loose or disconnected should be fixed. Replace the wires if necessary.
2. Fuse

- a) Blown fuses will measure OL. A spare F1 fuse is included with each control panel. Replace the fuse and check for power.

Power Loss – Sensors

Problem: One or more sensors do not power ON (but the control panel does).

Checks:

1. Power
 - a) Verify the incoming voltage is ~33 VDC
 - b) Check that all wires are secure in the correct terminals
 - c) Check that all harnesses are firmly connected
2. Fuse
 - a) Check for continuity across the main fuse (F1)

Solutions:

1. Power
 - a) If the incoming voltage is too high or low, replace the power source.
 - b) Any wires/harnesses that are loose or disconnected should be fixed. Replace the wire/harness if necessary.
2. Fuse
 - a) Blown fuses will measure OL. A spare F1 fuse is included with each detector. Replace the fuse and check for power.

Black Display with Power On

Problem: The relay board has power but the display is still black.

Checks:

1. Verify the display power cable is connected to both the connector on the relay board and the barrel plug on the back of the touchscreen
2. Ensure the negative wire in the power cable goes to the bottom pin of the display power connector
3. Check that the boot switch is set to “eMMC” and not “μSD”
4. Look for blue lights on the back of the touchscreen
5. Look for a green light on the front of the touchscreen (but behind the door)

Solutions:

1. The display power cable must remain connected at all times during operation.
2. If the wires are flipped on the display power cable, replace the cable with a new, correct cable. Alternatively, use a small prying tool to depress the pins in the connector and release the wires. Then insert them back into the connector with the correct orientation.
3. If the boot switch is in the wrong position, flip the switch and cycle power.
4. If no blue lights are present, replace the touchscreen assembly.
5. If blue lights are present but no green light is present, attempt to update the control panel firmware. If this update does not succeed, replace the touchscreen assembly.

Equipment Runs Constantly

Problem: Ventilation or warning equipment connected to one or more of the control panel relays runs constantly.

Check: Verify the relay opens and closes with the self-test mode.

Solution: If the relay opens and closes during a manual override, either change the relay level or exchange the wires between NO and NC.

Equipment Activates at the Wrong Time

Problem: Ventilation or warning equipment does not activate when desired.

Check: Verify the equipment is connected to the appropriate relays and that the alert/delay settings are as desired.

Solution: Move the equipment wiring to the correct relay terminals and adjust the alert/delay settings as needed.

Equipment Does Not Activate

Problem: Ventilation or warning equipment does not activate at all.

Check:

1. Control Panel
 - a) Verify the equipment is connected to the appropriate relays
 - b) Check that sensors are assigned to the appropriate zones
 - c) Use manual override to verify relay operation
 - d) Measure relay fuses to check for blown fuses

2. Ventilation/Warning Equipment
 - a) Verify the equipment is wired properly
 - b) Ensure the equipment has the proper input voltage

Solution:

1. Control Panel
 - a) Equipment connected to the wrong relays or zones will not be activated by the control panel. Fix wiring connections and/or change the settings to resolve the issue.
 - b) If any relay fuses are blown, verify that the equipment is not drawing too much current through the fuses. Relay fuses are only rated for 5 A @ 125 VAC. External relays, motor starters, contactors, etc. may need to be installed.
 - c) If the relay state never changes during a manual override and the relay fuse is intact, replace the relay board.
2. Ventilation/Warning Equipment
 - a) Control panel relays are dry contacts and do not provide control voltage. If equipment requires voltage, this must be properly supplied and routed through the relays.

Relays Deactivate when Other Relays Activate

Problem: Equipment shuts down when gas levels continue to rise above a higher setpoint.

Check: Verify the relay level of each relay in *Relay Settings*.

Solution: Any equipment that should remain active at the same time must be connected to relays of the same level. Adjust the relay levels as necessary.

Proportional Output Provides the Wrong Signal

Problem: The proportional output provides the wrong signal.

Check: Verify the jumpers on JP1 match the desired setting.

Solution: Move the jumpers on JP1 to the desired setting.

Proportional Output Provides a Constant Signal

Problem: The proportional output provides a constant signal.

Check:

1. Settings
 - a) Verify that JP1 is set to the appropriate set of pins.
2. Power
 - a) Verify that the relay board has power
 - b) Measure voltage/resistance between TP4 and TP3
 - c) On a sensor board, measure voltage between TP1 or TP7 and TP3 while applying test gas

Solution:

1. Settings
 - a) Move the jumper on JP1 to the desired setting
2. Power
 - a) If the relay board does not have power, the proportional output will not work. Troubleshoot the power loss and check again.
 - b) If the relay board has been damaged by shorting 5 V to GND, the proportional output will not change. Replace the relay board and ensure that no damage is being caused by the device connected to the proportional output prior to making any connections.
 - c) If the voltage at TP1 or TP7 does not change on a sensor board, neither will the proportional output. Verify the test gas and sensor operation.
 - i. If the test gas is wrong, try again using the correct setup.
 - ii. If the sensor does not respond to gas, replace the sensor board.
 - d) If the voltage at TP1 or TP7 does change but the proportional output does not, replace the sensor board.

Gas Readings are Unsatisfactory

Problem: The control panel does not register the desired concentration of target gas.

Check: None

Solution: Recalibrate or replace any sensor modules as required.

Replacement Parts

Below is a list of parts that may be replaced inside Brasch products. Please consult your local Brasch representative for pricing and availability.

Product Type	Part Number	Part Description
Standalone Detector	GSE2-F5A	5 A, 250 VAC Relay Fuse
	GSE2-F04A	0.4 A, 250 VAC Main Fuse (120 V)
	GSE2-F2A	2 A, 250 VAC Main Fuse (24 V)
	GSE2-F1A	1 A, 250 VAC Main Fuse
	GSE2-CTL	Control Board
	GSE2-INT-120	120 VAC Interface Board
	GSE2-INT-24	24 VAC Interface Board
	GSE2-3CONN	3-Wire Power Harness
	GSE2-8CONN	8-Wire Relay Harness
	GSE2-5CONN	5-Wire Local Sensor Harness
	GSE2-RCONN	5-Wire Remote Sensor Harness
Multi-Zone Control Panel	GDCP-F5A	5 A, 250 VAC Relay Fuse
	GDCP-F1A	1 A, 250 VAC Main Fuse
	GDCP-RELAY	Relay Board
	GDCP-TSA	Touchscreen Assembly
	GDCP-SD	32 GB MicroSD Card
	GDCP-BATTERY	3 V CR2012 Battery
	GDCP-BARREL	Display Power Barrel Connector
	GDCP-FILTER	AC Input Line Filter
Universal Transmitter	GEN2-F1A	1 A, 250 VAC Main Fuse
	GEN2-PCB	Sensor Board
	MOD-CM	Carbon Monoxide Sensor Module
	MOD-ND	Nitrogen Dioxide Sensor Module
	MOD-ME	Methane Sensor Module
	MOD-PR	Propane Sensor Module
	MOD-HY	Hydrogen Sensor Module
	MOD-OX	Oxygen Sensor Module

Replacing Sensor Boards of Different Revisions

Revision A through G sensor boards and Revision H sensor boards are visually distinct, yet functionally identical. Revision H may be used in conjunction with and/or in place of Revision A through G. Wiring harnesses, terminal blocks, and analog outputs should be connected in the same fashion on both styles of sensor boards. See below for the correct conversions.

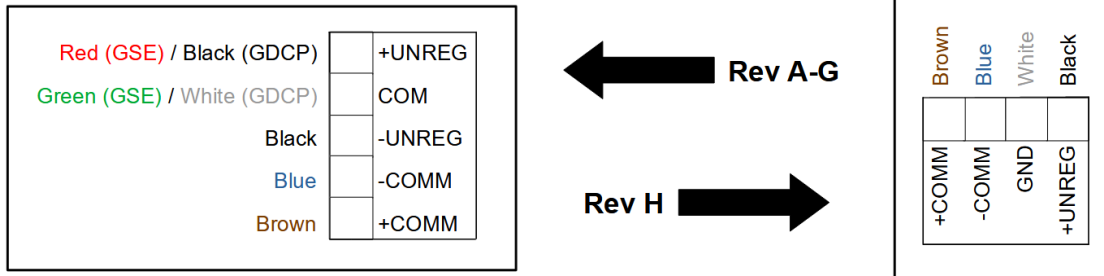

Rev A-G



Rev H

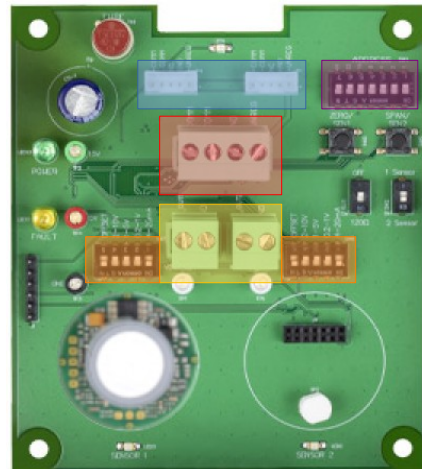

Legend		
JP1	Wiring Harness	JP1/JP4
TS1/TS2	Terminal Blocks	TS1
TS3	Analog Outputs	TS3/TS4
JP2/JP3	Analog Output Settings	SW6/SW7
SW1	Addressing	SW1

Appendix

Control Board Layout

Legend

TP2: 5 VDC

TP3: COM

SW1/SW2: Zone 1 Delay/Alert

SW3: Active Sensors Switch

SW4: Zone Assign Switches

SW9/SW10: Zone 2 Delay/Alert

JP3: Interface Relay Connector

JP5/JP10: Fan Speed Jumpers

JP8/JP9: Sensor Connectors

JP11: Interface Power Connector

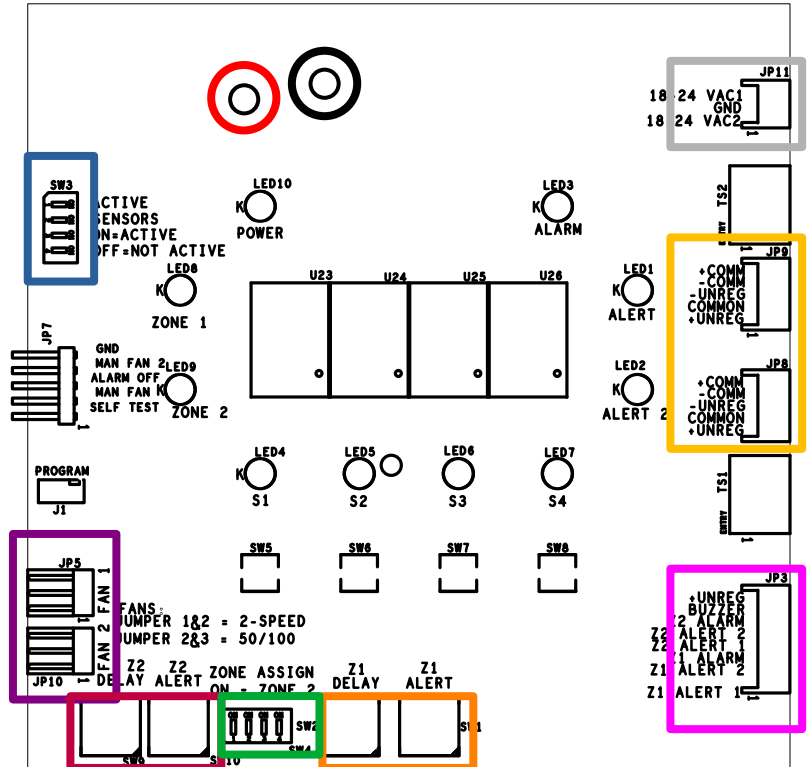

Figure 1: Control Board Layout

Acceptable Measurements

When taking measurements, use TP3 – COM as the reference unless otherwise specified. Voltage measurements must be taken with power ON. Resistance measurements must be taken with power OFF.

TP2: 5 VDC / > 0.5 kΩ

18-24 VAC1: > 18 VAC and < 27 VAC / > 100 kΩ

18-24 VAC2: > 18 VAC and < 27 VAC / > 100 kΩ

+COMM (Brown): > 100 kΩ (~same as below)

-COMM (Blue): > 100 kΩ (~same as above)

+COMM to -COMM: > 400 kΩ without termination resistor / 120 Ω with termination resistor

Sensor Board Layout

Legend

TP2: +15 VDC

TP3: COM

TP4: 5 VDC

TP5: Status

TP7: Sensor 1 Output Voltage

TP1: Sensor 2 Output Voltage

F1: 1 A – Main Fuse

SW1: Address Switches

SW2: Sensor Selection Switch

SW3: End-of-Line Resistor Switch

SW4/SW5: Calibration Buttons

SW7: Sensor 1 Proportional Output

SW6: Sensor 2 Proportional Output

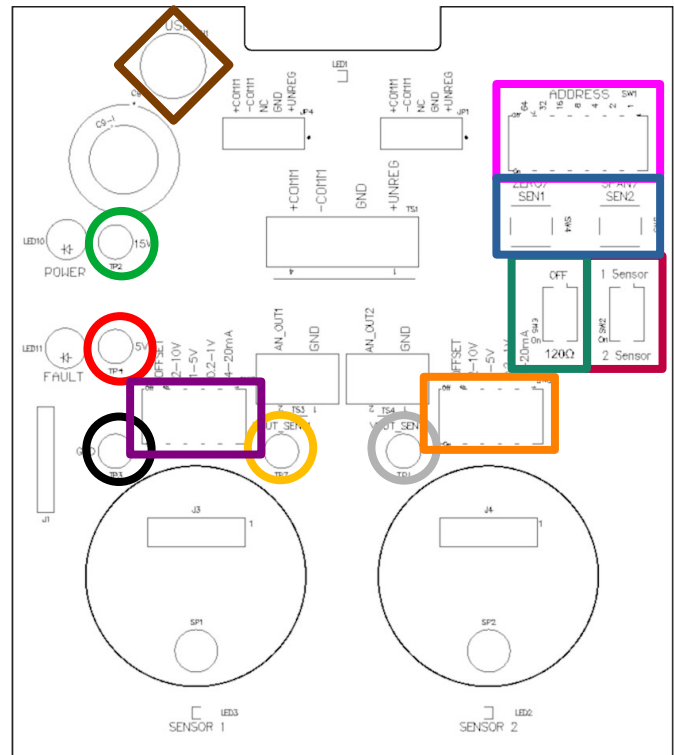

Figure 2: Sensor Board Layout

Acceptable Measurements

When taking measurements, use TP3 – COM as the reference unless otherwise specified. Voltage measurements must be taken with power ON. Resistance measurements must be taken with power OFF.

TP2: 15 VDC / > 2 k Ω

TP4: ~5 VDC / > 0.5 k Ω

TP7: ~0.8-4.0 VDC (proportional to gas concentration) / > 100 k Ω

TP1: ~0.8-4.0 VDC (proportional to gas concentration) / > 100 k Ω

+COMM (Brown): > 50 k Ω (~same as below)

-COMM (Blue): > 50 k Ω (~same as above)

+COMM to -COMM: > 200 k Ω without termination resistor / 120 Ω with termination resistor

Fuse: < 10 Ω

Interface Board Layout

Legend

F1: 2 A – Main Fuse (24 VAC)

F1: 400 mA – Main Fuse (120 VAC)

F2-F7: 5 A – Relay Fuses

SW1: Power Switch

TS1: Power Input

TS2: Zone 1 Relays

TS3: Zone 2 Relays

JP2: Control Relay Connector

JP3: Control Power Connector

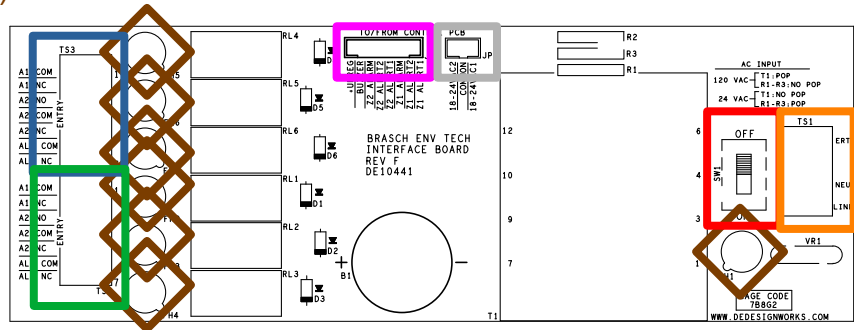

Figure 3: Interface Board Layout

Acceptable Measurements

Voltage measurements must be taken with power ON. Resistance measurements must be taken with power OFF.

18-24 VAC1: > 18 VAC and < 27 VAC / > 1 M Ω

18-24 VAC2: > 18 VAC and < 27 VAC / > 1 M Ω

Fuses: < 10 Ω

Relays: Open / Closed = OL / 0 Ω

Relay Board Layout

Legend

TP1: +UNREG

TP2: 5 VDC – Display Power

TP3: 5 VDC – Logic Power

TP4: GND

TS7: Incoming COMM

TS8/TS11: Outgoing COMM

F1: 1 A – Main Fuse

F2-F5: 5 A – Relay Fuses

SW1: Address Switches

SW2: Power Switch

SW3/SW4: Bias/Termination Resistors

JP1: Proportional Output Scale

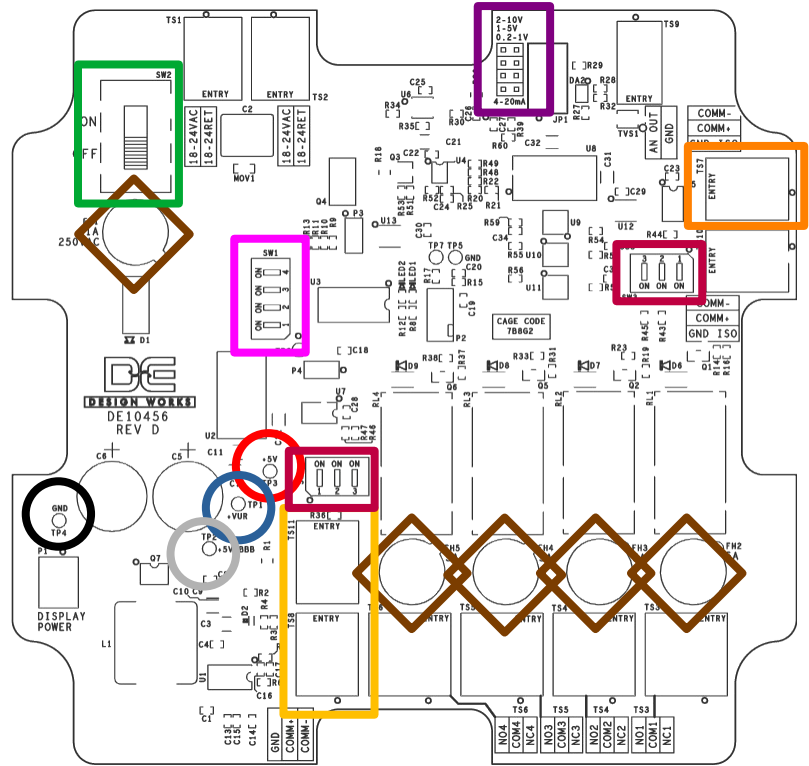

Figure 4: Relay Board Layout

Acceptable Measurements

When taking measurements, use TP4 – GND as the reference unless otherwise specified. Voltage measurements must be taken with power ON. Resistance measurements must be taken with power OFF.

TP1: 33 VDC / > 100 k Ω

TP2: 5 VDC / > 1 k Ω

TP3: 5 VDC / > 1 k Ω

+COMM (Brown): > 100 k Ω (~same as below)

-COMM (Blue): > 100 k Ω (~same as above)

+COMM to -COMM: > 400 k Ω without termination resistor / 120 Ω with termination resistor

Fuses: < 10 Ω

Relays: Open / Closed = OL / 0 Ω

Addressing

Sensor Board

Each sensor board has a 7-position DIP switch (SW1) used to set the device address. Available addresses are 1 through 128. The address of the first sensor is the value of the DIP switches plus one. If there are two sensors enabled on one board, the second sensor takes the address of the DIP switches plus two.

Brasch sensor boards are programmed and configured at the factory so that it should not be necessary to alter addresses in the field. Each unit will indicate the address assigned at the factory on its front cover label. However, these addresses can be modified by using the DIP switch on the top, right side of the circuit board. The address is assigned using a binary counting system where digit 0 is towards the top of the board and 1 is towards the bottom. Refer to figure 5 below for details.

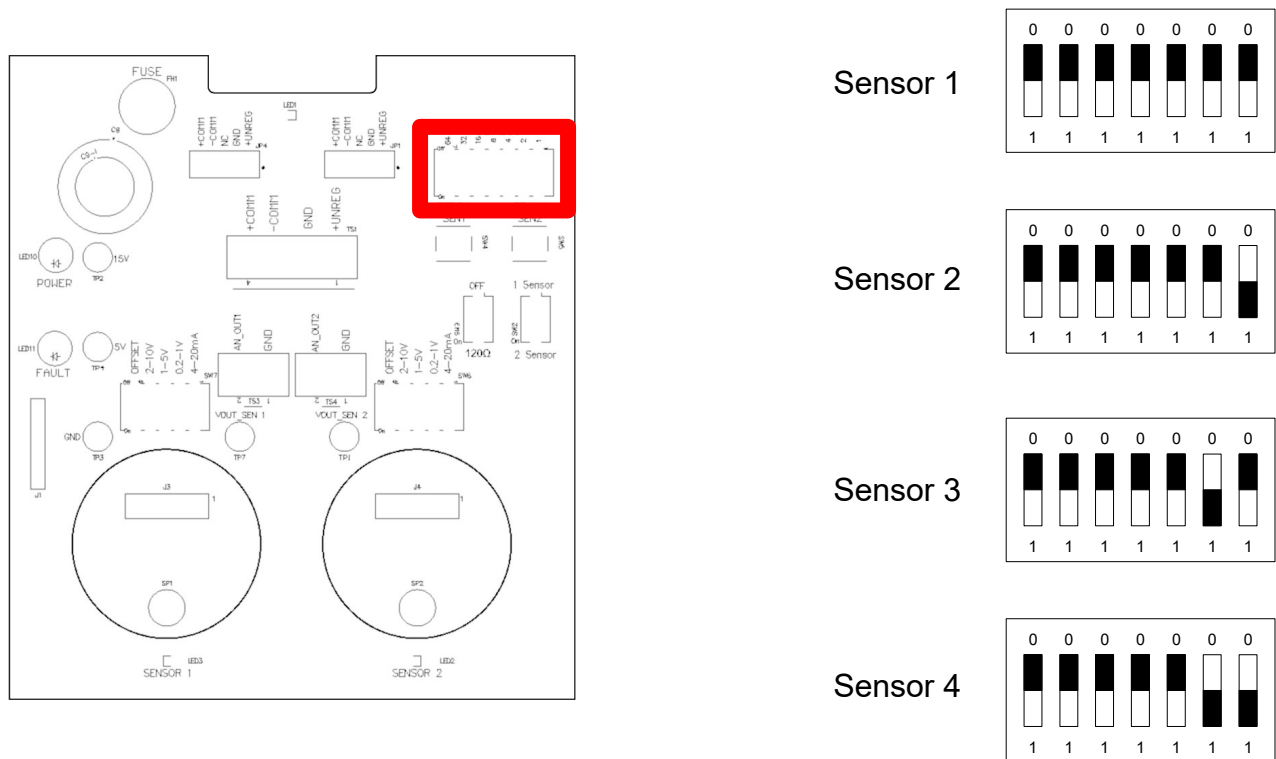

Figure 5: Sensor Board Addressing (1 through 4)

For a complete list of switch positions and addresses, see figure 6 on the following page.

Sensor Address	Switch Position	Sensor Address	Switch Position	Sensor Address	Switch Position	Sensor Address	Switch Position
1	0000000	33	0100000	65	1000000	97	1100000
2	0000001	34	0100001	66	1000001	98	1100001
3	0000010	35	0100010	67	1000010	99	1100010
4	0000011	36	0100011	68	1000011	100	1100011
5	0000100	37	0100100	69	1000100	101	1100100
6	0000101	38	0100101	70	1000101	102	1100101
7	0000110	39	0100110	71	1000110	103	1100110
8	0000111	40	0100111	72	1000111	104	1100111
9	0001000	41	0101000	73	1001000	105	1101000
10	0001001	42	0101001	74	1001001	106	1101001
11	0001010	43	0101010	75	1001010	107	1101010
12	0001011	44	0101011	76	1001011	108	1101011
13	0001100	45	0101100	77	1001100	109	1101100
14	0001101	46	0101101	78	1001101	110	1101101
15	0001110	47	0101110	79	1001110	111	1101110
16	0001111	48	0101111	80	1001111	112	1101111
17	0010000	49	0110000	81	1010000	113	1110000
18	0010001	50	0110001	82	1010001	114	1110001
19	0010010	51	0110010	83	1010010	115	1110010
20	0010011	52	0110011	84	1010011	116	1110011
21	0010100	53	0110100	85	1010100	117	1110100
22	0010101	54	0110101	86	1010101	118	1110101
23	0010110	55	0110110	87	1010110	119	1110110
24	0010111	56	0110111	88	1010111	120	1110111
25	0011000	57	0111000	89	1011000	121	1111000
26	0011001	58	0111001	90	1011001	122	1111001
27	0011010	59	0111010	91	1011010	123	1111010
28	0011011	60	0111011	92	1011011	124	1111011
29	0011100	61	0111100	93	1011100	125	1111100
30	0011101	62	0111101	94	1011101	126	1111101
31	0011110	63	0111110	95	1011110	127	1111110
32	0011111	64	0111111	96	1011111	128	1111111

Figure 6: Sensor Board Addresses and Switch Positions

Relay Board

Each relay board has a 4-position DIP switch (SW1) used to set the device address. Available addresses are 1 through 8. The address is the value of the DIP switches plus one.

Brasch relay boards are programmed and configured at the factory so that it should not be necessary to alter addresses in the field. Each unit will indicate the address assigned at the factory on the label. However, these addresses can be modified by using the DIP switch near the middle of the circuit board. The address is assigned using a binary counting system where digit 0 is towards the right of the board and 1 is towards the left. Figure 7 below shows addressing for all 8 relay boards.

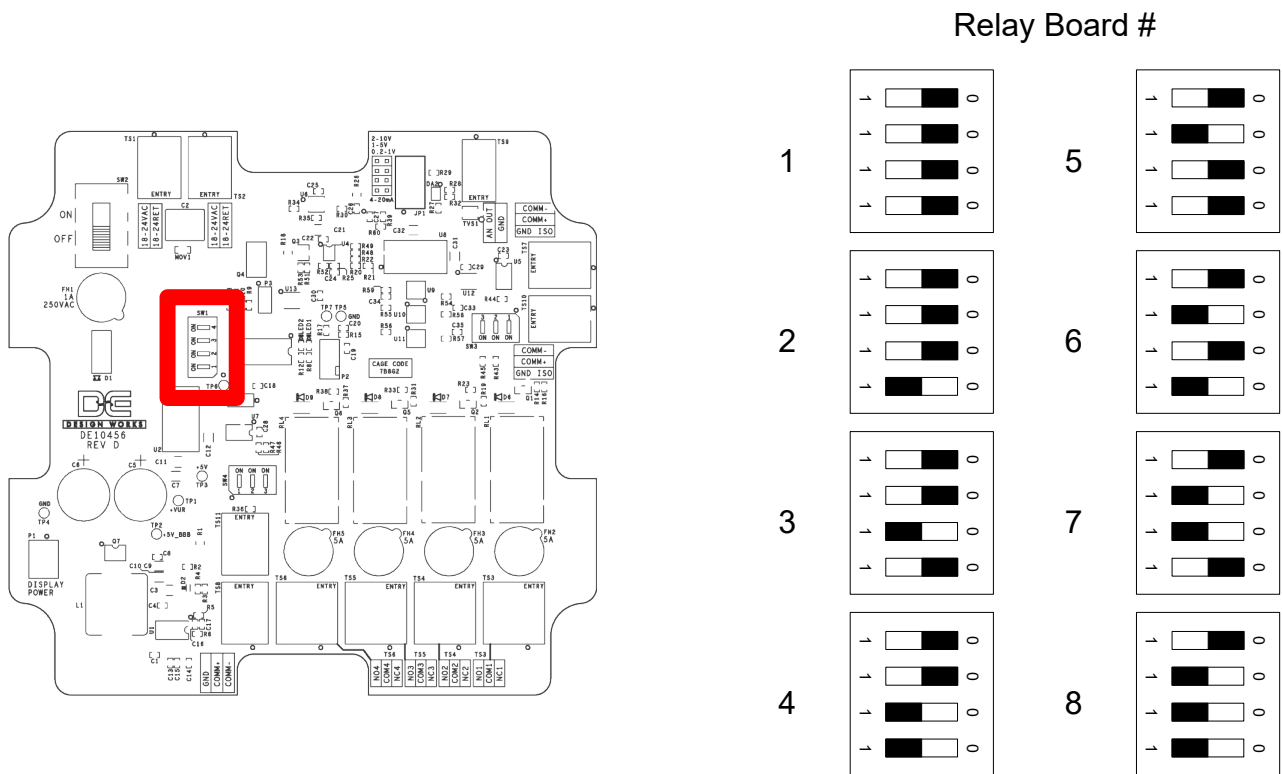

Figure 7: Relay Board Addressing (1 through 8)

Troubleshooting Flowchart

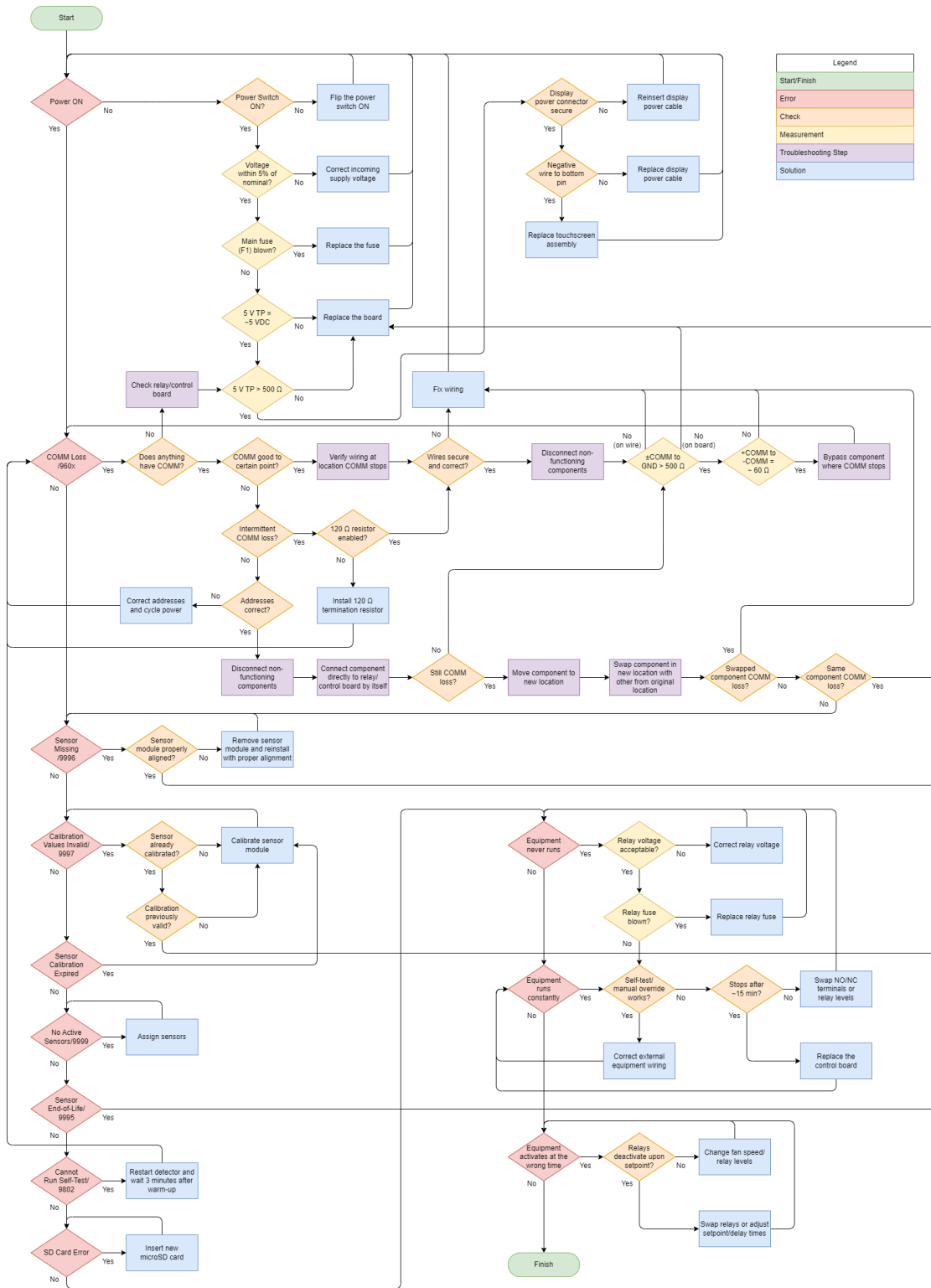

Figure 8: Troubleshooting Flowchart

Acceptable Measurements Reference

	Measurement	Positive Lead	Negative Lead	Good Range (Voltage)	Good Range (Resistance)
Control Board	Logic Voltage	TP2	TP3	4.9-5.3 VDC	> 0.5 kΩ
	Incoming Power	18-24 VAC1/ 18-24 VAC2	TP3	18-27 VAC	> 100 kΩ
	Positive COMM	JP8/9 +COMM	TP3		> 100 kΩ (~↓)
	Negative COMM	JP8/9 -COMM	TP3		> 100 kΩ (~↑)
	COMM Bus	JP8/9 +COMM	JP8/9 -COMM		> 400 kΩ (w/o resistor) 110-130 Ω (w/ resistor)
Interface Board	Incoming Power	18-24 VAC1/ 18-24 VAC2	TP3	18-27 VAC	> 1 MΩ
Relay	Relay Continuity	Relay Output	Relay COM		OL (Open) < 10 Ω (Closed)
Fuse	Fuse Continuity	Fuse Lead 1	Fuse Lead 2		< 10 Ω
Relay Board	Unregulated Input Voltage	TP1	TP4	31-35 VDC	> 100 kΩ
	Logic Voltage	TP3	TP4	4.9-5.3 VDC	> 500 Ω
	Display Power	TP2	TP4	4.9-5.3 VDC	> 1 kΩ
	Positive COMM	TS8/11 +COMM	TP4		> 100 kΩ (~↓)
	Negative COMM	TS8/11 -COMM	TP4		> 100 kΩ (~↑)
	COMM Bus	TS8/11 +COMM	TS8/11 -COMM		> 400 kΩ (w/o resistor) 110-130 Ω (w/ resistor)
Sensor Board	Regulated 15 V	TP2	TP3	14.5-15.5 VDC	> 2 kΩ
	Logic Voltage	TP4	TP3	4.9-5.3 VDC	> 500 Ω
	Sensor 1 Output Voltage	TP7	TP3	0.75-0.85 VDC (at Zero)	> 100 kΩ (~↓)
	Sensor 2 Output Voltage	TP1	TP3	0.75-0.85 VDC (at Zero)	> 100 kΩ (~↑)
	Positive COMM	+COMM	TP3		> 50 kΩ (~↓)
	Negative COMM	-COMM	TP3		> 50 kΩ (~↑)
	COMM Bus	+COMM	-COMM		> 200 kΩ (w/o resistor) 110-130 Ω (w/ resistor)
System (Relay Board + Sensor Boards)	Positive COMM	+COMM	GND/COM		> 500 Ω (~↓)
	Negative COMM	-COMM	GND/COM		> 500 Ω (~↑)
	COMM Bus	+COMM	-COMM		60-110 Ω
	½ COMM Bus	+COMM	-COMM		110-130 Ω
	Continuity	End of Wire	End of Wire		< 10 Ω

Figure 9: Acceptable Measurements Reference

Limited Warranty

Warranty Statement

Brasch Environmental Technologies, LLC warrants gas transmitters, gas detectors, control panels, and accessories for a period of two years from the date of shipment against defects in material or workmanship. Should any evidence of defects in material or workmanship occur during the warranty period, Brasch Environmental Technologies will repair or replace the affected product, at its own discretion, without charge. The company shall not be held responsible for any charges incurred with removal or replacement of allegedly defective equipment, nor for incidental or consequential damages. If any equipment has not been installed per Brasch instructions, this warranty is void. The cost to repair, replace, or service any component is not the responsibility of Brasch. Any replacement parts or service necessary must be paid in full prior to shipment or performance.

Service and Repair Procedures

Our goal at Brasch Environmental Technologies is to produce products that constantly exceed the requirements and expectations of our customers. One of the ways of meeting that goal is to produce products that never fail or require service. However, when we are notified of a problem with one of our products, it is our intention to address the problem as quickly and efficiently as possible.

Many problems that appear at first to be associated with the product can be solved without returning the product. If you experience a problem and would like to discuss it with a factory service technician, you may call the number listed on the product label. You will be transferred to a technician specially trained to service that product. This technician will help you determine the most efficient way of solving the problem.

If service or repair of your Brasch product becomes necessary, an authorization request for returning the product to the Brasch factory must be obtained from our sales office. If you are an end user, please contact your Brasch distributor to initiate this request. The distributor, after obtaining a description of the problem, will contact the factory and request a Return Goods Tag (RGT) number. This number must be placed in a conspicuous location on the outside of the shipping package. Without this RGT number, Brasch will not accept the shipment. A brief description of the reason for returning the product should be included in the package. Without this description, repair may take longer than necessary.

You may, at the time you request service, request an estimate on the time it will take for repair. The Brasch representative will give you an estimate based upon the information you provide. Although Brasch Environmental Technologies, LLC will repair and return your product in as short a time as possible, Brasch cannot be held responsible for meeting repair estimates.



BRASCH
ENVIRONMENTAL TECHNOLOGIES

140 Long Road, Suite 101
Chesterfield, Missouri 63005

General Contact Information

Phone: 314-291-0440
Fax: 314-291-0646
Email: customerservice@braschenvtech.com
Website: www.braschenvtech.com

Technical Support Contact Information

Phone: 314-291-0440 Option 2
Fax: 314-291-0646
Email: support@braschenvtech.com
Website: www.braschenvtech.com/contact

Revision: 3.0
Issue Date: February 24, 2026
Document Number: FG05
© Brasch Environmental Technologies, LLC
All Rights Reserved