



BRASCH

ENVIRONMENTAL TECHNOLOGIES

Modbus Installation and Setup Guide



Brasch Environmental Technologies, LLC
140 Long Road, Suite 101
Chesterfield, Missouri 63005
314-291-0440
www.braschenvtech.com

Table of Contents

Operation Safety Notice.....	3
Types of Notices.....	3
Introduction.....	4
General Description.....	4
Features.....	4
Installation.....	5
Wiring.....	5
Setup.....	7
Master/Client/Host Setup.....	7
Sensor Board Setup.....	8
Relay Board Setup.....	10
Modbus Register Allocation.....	11
Function 04 – Read Input Registers.....	11
Function 16 – Preset Multiple Registers.....	12

Operation Safety Notice

Certain procedures and operations detailed in this guide require that specific precautions be taken prior to beginning the procedure or operation. When precautions are required, a notice will be printed in an appropriate location in the guide. The user is urged to read and understand all such notices.

Types of Notices

Three types of notices may be used in this guide to describe the severity of the situation encountered.

WARNING: This notice indicates that conditions exist that could cause personal injury or loss of life.

CAUTION: Conditions exist that could cause damage to the equipment or other property.

Note: Special consideration should be given to the procedure or operation, otherwise an unexpected operational result could occur.

Introduction

General Description

Modbus is a messaging structure for establishing client-server communication between smart devices. It is an open standard and the most widely used network protocol in the industrial manufacturing environment. Modbus is used to monitor and program devices, communicate between sensors and instruments, and monitor field devices using PCs and HMIs.

Brasch sensor and relay boards communicate across a two-wire RS-485 bus using the Modbus RTU protocol. The data on this bus can be read by a remote device capable of interfacing with this protocol. In this configuration, the remote device is the client and the sensor or relay board is the server.

This document will serve as a reference for technical information pertaining to the installation and setup of the Brasch boards when used in a larger Modbus system. The following documents should also be used during this process:

- Brasch Gen 2 Remote Transmitter IOM: <https://braschenvtech.com/wp-content/uploads/2024/08/Gen2-Remote-Transmitter-IOM-Rev-2.pdf>
- Brasch GDCP-Touch IOM: <https://braschenvtech.com/wp-content/uploads/2024/08/GDCP-Touch-IOM-Rev-2.pdf>
- Modbus Manual: <https://www.modbus.org/file/secure/modbusprotocolspecification.pdf>

Use the following information to configure remote devices to communicate with a sensor or relay board.

Features

- Communicates using Modbus RTU
- Addressable with up to 128 unique sensor addresses and 16 unique relay addresses
- Supports Function Codes (FC) 04 and 16
- Provides gas sensor readings, error codes, relay control, and analog output overrides

Note

Modbus does not have a defined standard for communication with gas detection systems. As a result, the configuration is proprietary. Only the commands and registers listed in this document are available. Any unlisted commands and registers are assumed to be unused.

Installation

Wiring

The Brasch sensor board has one terminal block in the center of the circuit board. The leftmost terminal is +COMM; the connection point immediately to the right is -COMM. Refer to figure 1 on page 6 for details. The Brasch relay board has three terminal blocks for communication, two on the bottom left and one on the top right of the circuit board. Refer to figures 2 and 3 on pages 6 and 7 for details. Consider +COMM to be Data A and -COMM to be Data B when wiring to the terminals. Use a shielded twisted pair cable with color-coded wires to easily differentiate between the two terminals on each device. Brasch recommends the Belden 3105A (22 AWG) cable, but any similar shielded data communication cable will suffice.

CAUTION

Reversing the wiring connections to the Data A and B terminals of a device will prevent it from communicating and may interfere with the entire system as a result of the polarization. If this happens, swap the device's connections and retest the system.

Wire each device in a daisy chain configuration. The total distance should be no longer than 4000 feet. No more than 32 devices may be connected to a single bus, including the master/client/host. If more devices, or devices farther away than 4000 feet, need to be connected, repeaters may be used.

In order to avoid signal reflections, a 120 Ω termination resistor should be fitted/enabled at the master/client/host and at the farthest transmitter.

A bus configuration with branches connected to the main cable may also be used. However, there may be more limitations as the number of devices increases. The main cable should be no longer than 4000 feet with branches no longer than 3 feet. The combined length of all branches should not exceed 30 feet. Each main cable can have no more than 32 devices connected to it, including the master/client/host. As with the daisy chain, repeaters may be used to connect more devices or to increase the distance.

In order to avoid signal reflections, a 120 Ω termination resistor may be fitted on each end of the main cable.

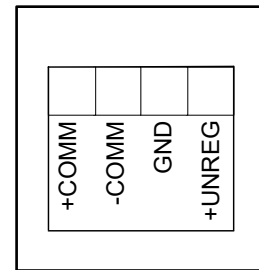
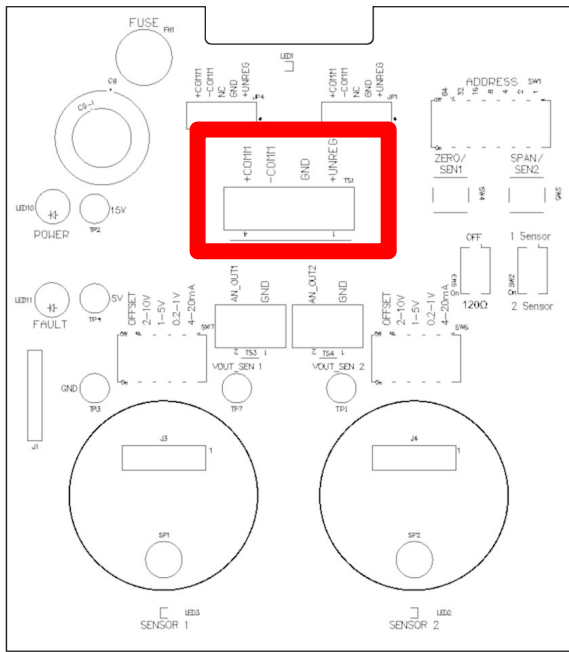
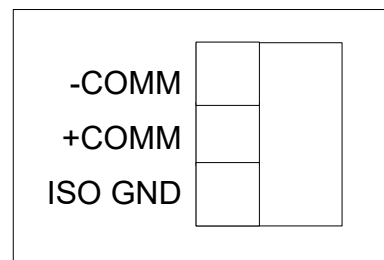
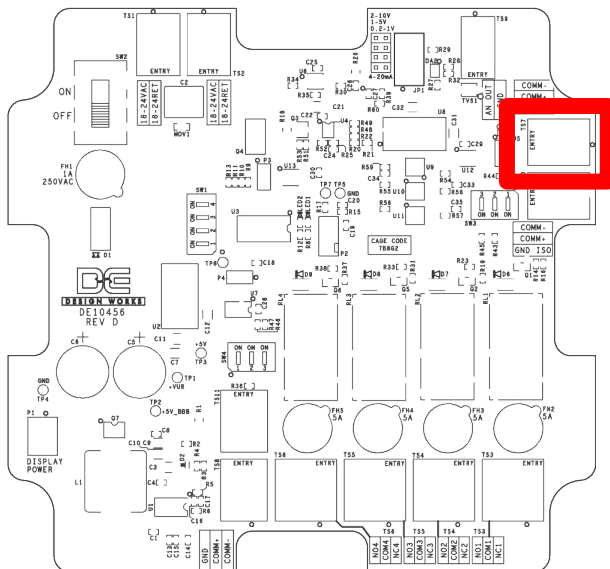

Figure 1: Sensor Board Communication Wiring



Isolated COMM (TS7)

Figure 2: Relay Board Communication Wiring – Input

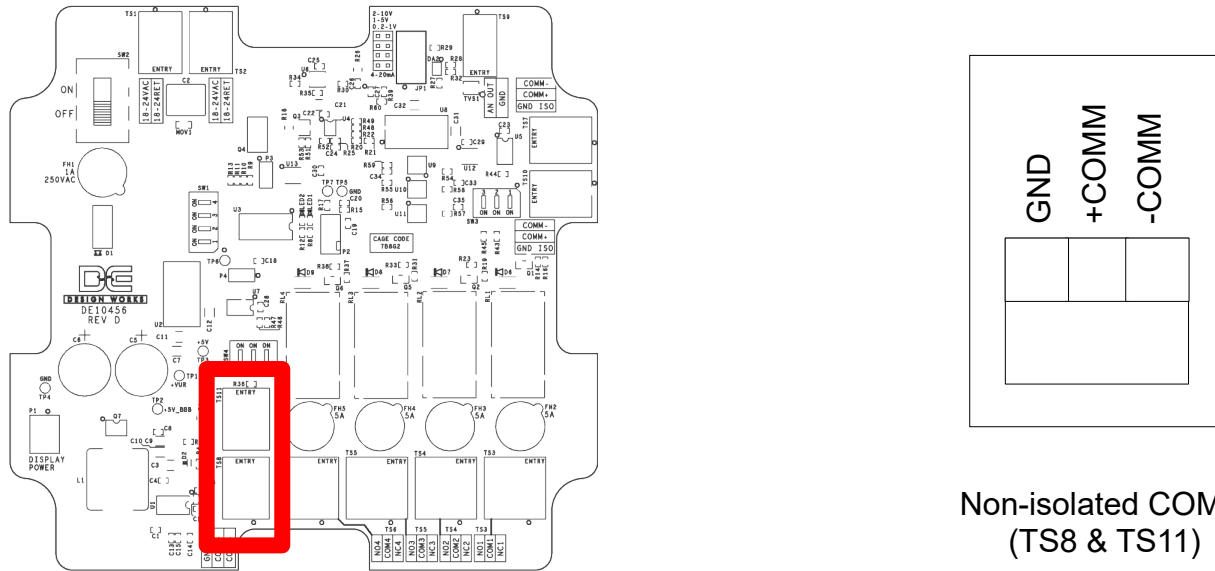

Figure 3: Relay Board Communication Wiring – Output

Setup

Master/Client/Host Setup

Before starting, please refer to the documentation included with the master/client/host device. It will contain the details of its communication along with instructions for Modbus configuration.

Brasch recommends that the master/client/host be configured to attempt at least two retries in the event of a communication frame loss with a minimum delay of one second between each poll and a minimum timeout of two seconds.

Use the information in figure 4 below to configure the master/client/host device.

Baud Rate	9600
Data	8 bits
Stop	1 bit
Parity	None
Flow Control	None

Figure 4: Master/Client/Host Setup Parameters

Sensor Board Setup

Each sensor board has a 7-position DIP switch (SW1) used to set the device address. Available addresses are 1 through 128. The address is the value of the DIP switches plus one.

Brasch sensor boards are programmed and configured at the factory so that it should not be necessary to alter addresses in the field. Each unit will indicate the address assigned at the factory on its front cover label. However, these addresses can be modified by using the DIP switch on the top, right side of the circuit board. The address is assigned using a binary counting system where digit 0 is towards the top of the board and 1 is towards the bottom. Refer to figure 5 below for details.

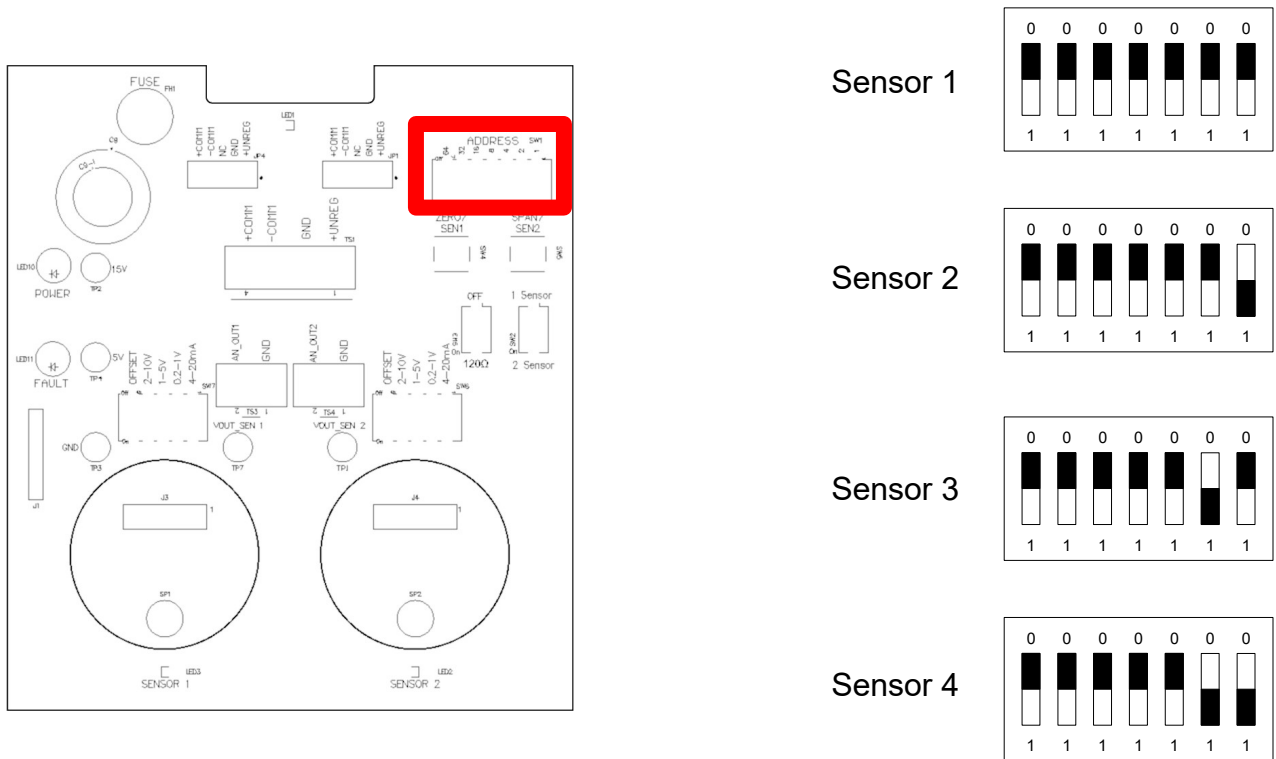

Figure 5: Sensor Board Addressing (1 through 4)

For a complete list of switch positions and addresses, see figure 6 on page 9.

Sensor Address	Switch Position	Sensor Address	Switch Position	Sensor Address	Switch Position	Sensor Address	Switch Position
1	0000000	33	0100000	65	1000000	97	1100000
2	0000001	34	0100001	66	1000001	98	1100001
3	0000010	35	0100010	67	1000010	99	1100010
4	0000011	36	0100011	68	1000011	100	1100011
5	0000100	37	0100100	69	1000100	101	1100100
6	0000101	38	0100101	70	1000101	102	1100101
7	0000110	39	0100110	71	1000110	103	1100110
8	0000111	40	0100111	72	1000111	104	1100111
9	0001000	41	0101000	73	1001000	105	1101000
10	0001001	42	0101001	74	1001001	106	1101001
11	0001010	43	0101010	75	1001010	107	1101010
12	0001011	44	0101011	76	1001011	108	1101011
13	0001100	45	0101100	77	1001100	109	1101100
14	0001101	46	0101101	78	1001101	110	1101101
15	0001110	47	0101110	79	1001110	111	1101110
16	0001111	48	0101111	80	1001111	112	1101111
17	0010000	49	0110000	81	1010000	113	1110000
18	0010001	50	0110001	82	1010001	114	1110001
19	0010010	51	0110010	83	1010010	115	1110010
20	0010011	52	0110011	84	1010011	116	1110011
21	0010100	53	0110100	85	1010100	117	1110100
22	0010101	54	0110101	86	1010101	118	1110101
23	0010110	55	0110110	87	1010110	119	1110110
24	0010111	56	0110111	88	1010111	120	1110111
25	0011000	57	0111000	89	1011000	121	1111000
26	0011001	58	0111001	90	1011001	122	1111001
27	0011010	59	0111010	91	1011010	123	1111010
28	0011011	60	0111011	92	1011011	124	1111011
29	0011100	61	0111100	93	1011100	125	1111100
30	0011101	62	0111101	94	1011101	126	1111101
31	0011110	63	0111110	95	1011110	127	1111110
32	0011111	64	0111111	96	1011111	128	1111111

Figure 6: Sensor Board Addresses and Switch Positions

Relay Board Setup

Each relay board has a 4-position DIP switch (SW1) used to set the device address. Available addresses are 129 through 144. The address is the value of the DIP switches plus 129.

Brasch relay boards are programmed and configured at the factory so that it should not be necessary to alter addresses in the field. Each unit will indicate the address assigned at the factory on the right side label. However, these addresses can be modified by using the DIP switch near the middle of the circuit board. The address is assigned using a binary counting system where digit 0 is towards the right of the board and 1 is towards the left. Figure 7 below shows addressing for the first 8 relay boards. Refer to figure 6 above for additional boards.

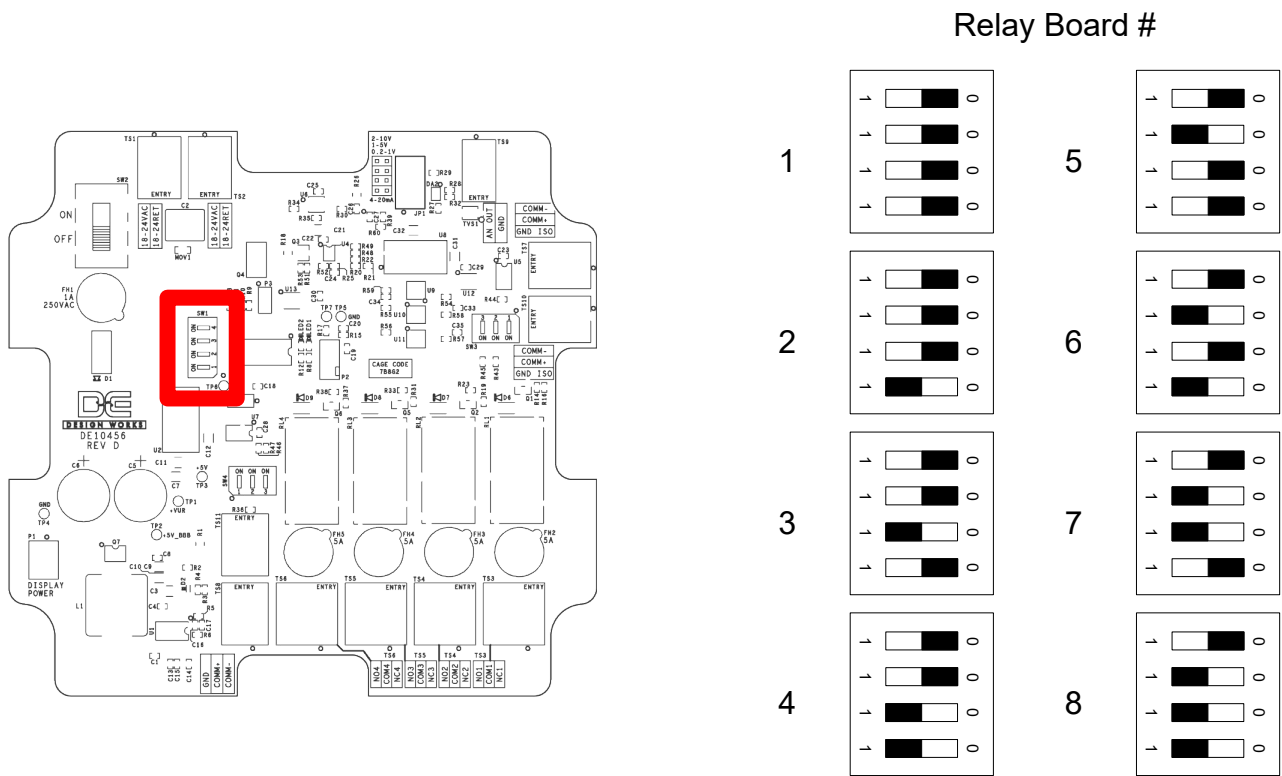

Figure 7: Relay Board Addressing (1 through 8)

Modbus Register Allocation

Function 04 – Read Input Registers

This function reads the content of an input register. Each value is represented as a 16-bit unsigned integer. Sensor boards support all listed indices. Relay boards only support reading the firmware version.

Index	Description	Scale	Units	Data
0	Firmware Version	-	-	High Byte = Major Version Low Byte = Minor Version
1	Gas Sensor Type	-	-	0x0000 = CO 0x0001 = NO ₂ 0x0004 = O ₂ 0x0006 = H ₂ 0x0008 = CH ₄ 0x0009 = C ₃ H ₈
2	Error Status	-	-	0x0001 = End of Life (EOL) 0x0002 = (Reserved) 0x0004 = Sensor Not Installed 0x0008 = Invalid Calibration Values 0x0010 = Calibration Expired 0x0080 = Warm-Up State
3	Gas Value	10	Varies	16-bit Value of Gas Measurement in PPM (CO/NO ₂), % LEL (Combustible), or % V/V (O ₂)

Figure 8: Input Registers

Function 16 – Preset Multiple Registers

This function is used to write a block of contiguous registers in a remote device. Sensor boards do not support this function. Relay boards support setting both relay state and analog output value.

Index	Description	Scale	Units	Data
0	Relay Board Outputs	-	-	High Byte = bit 7-4 (reserved) bit 3 – Relay #4 bit 2 – Relay #3 bit 1 – Relay #2 bit 0 – Relay #1 Low Byte = 0 – 255 (8-bit DAC)

Figure 9: Output Registers



BRASCH
ENVIRONMENTAL TECHNOLOGIES

140 Long Road, Suite 101
Chesterfield, Missouri 63005

General Contact Information

Phone: 314-291-0440
Fax: 314-291-0646
Email: customerservice@braschenvtech.com
Website: www.braschenvtech.com

Technical Support Contact Information

Phone: 314-291-0440 Option 2
Fax: 314-291-0646
Email: support@braschenvtech.com
Website: www.braschenvtech.com/support-for-existing-systems

Revision: 3.1
Issue Date: July 16, 2024
Document Number: SG01
© Brasch Environmental Technologies, LLC
All Rights Reserved