



BRASCH

ENVIRONMENTAL TECHNOLOGIES

GSE Generation 2

Quick Start Guide



Brasch Environmental Technologies, LLC
140 Long Road, Suite 101
Chesterfield, Missouri 63005
314-291-0440
www.braschenvtech.com

Quick Start Guide

Please read the entire manual before attempting to install and operate this gas detector. This guide is only intended to provide the basic steps necessary for installation and operation. Each step will reference the portion of the manual where more complete information can be obtained.

Step 1 – Mounting

Determine the location for mounting your detector(s). The location(s) may be indicated on the architectural drawing. Also, the owner or designer of the facility may be consulted. Mounting guidelines can be found on page 14 of the manual.

Step 2 – Input Wiring

WARNING

This detector may require the use of voltage levels high enough to cause fatal injuries. Proper procedures must be followed any time work is performed on this unit.

Only qualified personnel should attempt to install, maintain, or service this equipment.

Provide a dedicated circuit with the required operating voltage at each detector mounting location. Follow all national and local wiring codes. The wiring should be at least 14 AWG. A conductor connected to earth ground should also be provided for 120 VAC models. The circuit must include a disconnect switch located within easy reach of the detector.

If the detector operates from a voltage other than 120 VAC, ensure that the step-down transformer provides the correct secondary voltage and has the necessary volt-amp rating. The power requirement for the detector is listed on the front panel label.

CAUTION

Operating this detector with the incorrect voltage and power requirements can cause internal electrical components to overheat and fail. Operation with the wrong power requirement will void the manufacturer's warranty and the installer will be responsible for any damage that occurs.

Contact Brasch Environmental Technologies, LLC before connecting power to the detector if you are unsure of the correct power requirement.

Color-coded wires exiting the detector housing through the top, right conduit connector are provided for connecting the operating voltage to the detector. Therefore, it should not be necessary to open the cover on the detector when connecting the voltage supply. Connect the hot power conductor to the black wire, the neutral conductor to the white wire, and the ground conductor to the green wire (if present).

Refer to page 15 of the manual for more information.

Step 3 – Remote Transmitter Wiring

If remote transmitters are a part of this detector, the detector will supply the operating power to each transmitter. Use a four-conductor cable with color-coded conductors of at least 18 AWG to make the connection. Two of these conductors provide the positive voltage and reference common to the transmitter for power. The remaining two conductors carry the signal from the transmitter to the controller. These two signal conductors should be a shielded twisted pair (STP). See figure 10 on page 43 and figure 11 on page 44 for details. If possible, choose a cable with color-coded conductors that follow the suggested color scheme listed on the drawings.

CAUTION

It is very important that the power and signal connections between each transmitter and between the transmitters and the Brasch controller be correct. If the connections are wired incorrectly, damage to both the transmitters and the controller will occur.

Use a cable with color-coded conductors and make sure that the same conductor connects to the same terminal on each transmitter and the controller.

Do not apply power to the transmitter or controller unless you are sure that the connections are correct.

Multiple remote transmitters, regardless of gas type, should be connected in a daisy chain pattern. All transmitters share the same conductors back to the controller. Therefore, a four-conductor cable can be connected from transmitter to transmitter, or from transmitter to controller, as the situation dictates. In either case, ensure the communication wires are a twisted pair and shielded from the power conductors. Separate cables may be used as necessary. Follow the wiring diagrams on page 43 and 44 of the manual to determine the proper connections at the controller. On the transmitter farthest from the controller, enable the RS485 termination resistor (SW3) to reduce signal reflections.

Step 4 – Relay Wiring

In most cases, wiring of the ventilation control relays can be completed without opening the front panel of the detector. Color-coded wires connected to the internal relay terminals extend outside the housing through the conduit connector located at the top, left of the unit. Use only the necessary wires required for control of the ventilation components. Cover or seal the ends of any unused wires and place them safely inside the conduit or electrical box.

Determine the type and number of fans and/or make-up air units the detector will control. For proper installation, you must first determine how and when the fans/make-up air units will operate. Many installations have only one or two ventilation components designed to operate simultaneously. These components usually operate from the A1 terminals of the Low Alert relay. Other ventilation systems contain multiple components designed to operate in two stages. Connect the primary ventilation components to the A1 terminals of the Low Alert relay using the yellow wires and the secondary components to the A2 terminals of the High Alert relay using the brown wires. When using multiple zones, follow the same guidelines as above using the red wires for A1 and blue wires for A2 of Zone 2. Note that while the Low Alert and Alarm relay contacts are labeled NC, they will open when power is applied and close upon a rise in gas. This allows the detector to fail safely in the event of power loss or any error condition.

All relays are dry contacts. Do not exceed the specified voltage and power limits of the relays (see page 6 of the manual). Most installations require motor starters or larger relays to provide the necessary power requirements for the ventilation components.

For more information concerning ventilation system operation, read page 17 of the manual.

Step 5 – External Alarms

Determine if the installation requires an external alarm. If so, provide the proper wiring and connect the wires to the required voltage source. Connect the wiring to the Alarm relay(s) using the gray wires for Zone 1 and purple wires for Zone 2.

Refer to page 18 in the manual for more information concerning the alarm feature.

Step 6 – Applying Power

Once you are sure that the wiring connections are correct, apply power to the detector circuit. When power is first applied, the unit will display the firmware version for five seconds before entering normal operation. When the sensors are powered at the same time as the controller, the display will show dashes until the sensors exit their warm-up phase. The green Power LED will remain solid and the yellow LEDs will begin to alternate according to how many zones

and sensors are present. Upon sensors exiting warm-up, the dashes will be replaced by a numeric readout of the gas concentration or any errors present.

See page 18 in the manual for more information concerning the initial startup.

Step 7 – Self-Test Mode

This detector is equipped with a self-test mode that can be activated any time after warm-up by pressing the “SELF TEST” button for approximately one second. This mode will test the display, indicator LEDs, relays, and buzzer for proper operation. Any ventilation components connected to these relay terminals will operate if their power supply is active. The ventilation component relays will remain on for 30 seconds to allow sufficient time for testing if problems occur. There is a 30 second period between each relay actuation. At the end of this test, the buzzer will sound for three seconds and the detector will resume normal operation as described in step 6.

Page 19 in the manual contains a more complete discussion of this self-test mode.

At this point, the detector is now ready to monitor for the presence of the target gas(es) and control the ventilation system to efficiently remove the gas from the protected area.

Warranty Statement

Brasch Environmental Technologies, LLC warrants gas transmitters, gas detectors, control panels, and accessories for a period of two years from the date of shipment against defects in material or workmanship. Should any evidence of defects in material or workmanship occur during the warranty period, Brasch Environmental Technologies will repair or replace the affected product, at its own discretion, without charge. The company shall not be held responsible for any charges incurred with removal or replacement of allegedly defective equipment, nor for incidental or consequential damages. If any equipment has not been installed per Brasch instructions, this warranty is void. The cost to repair, replace, or service any component is not the responsibility of Brasch. Any replacement parts or service necessary must be paid in full prior to shipment or performance.

Typical Installation Diagrams

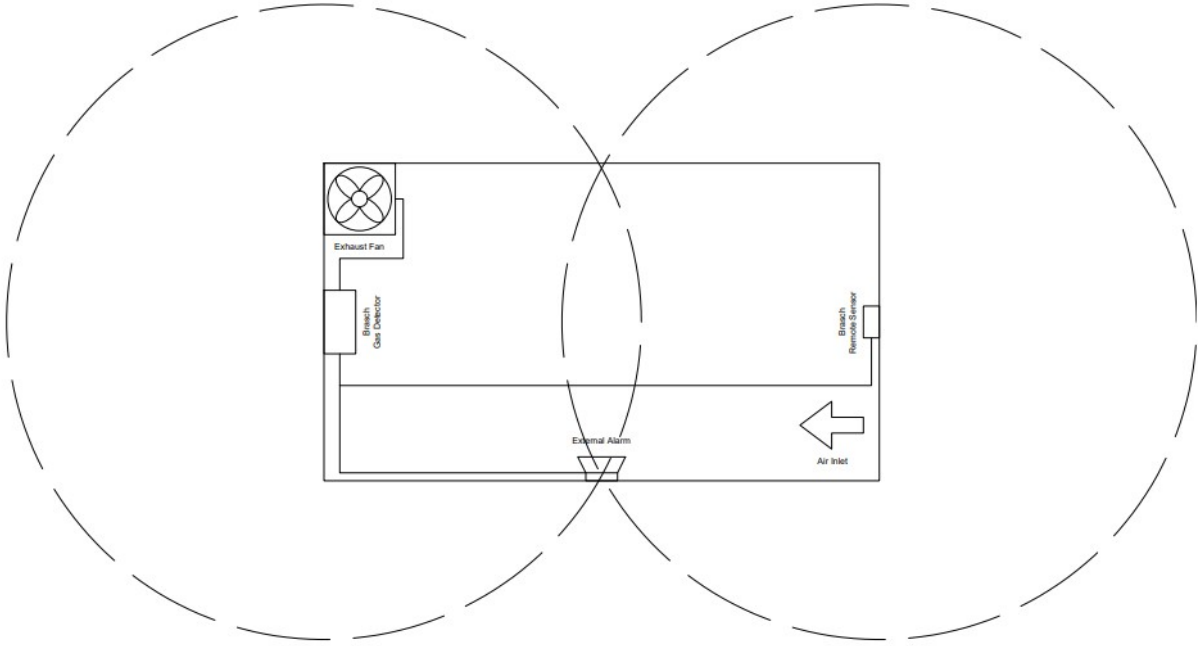

Figure 1: Wiring – Typical Layout

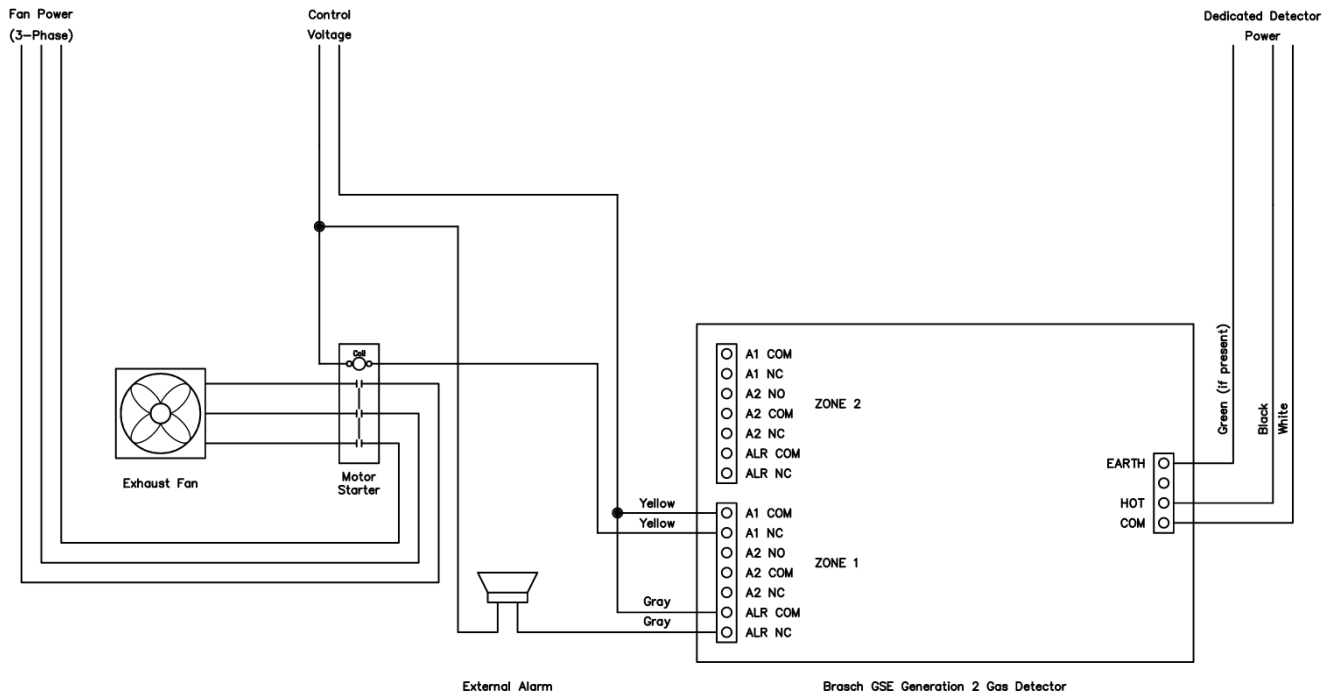

Figure 2: Wiring - Single Fan Ventilation System with One Zone

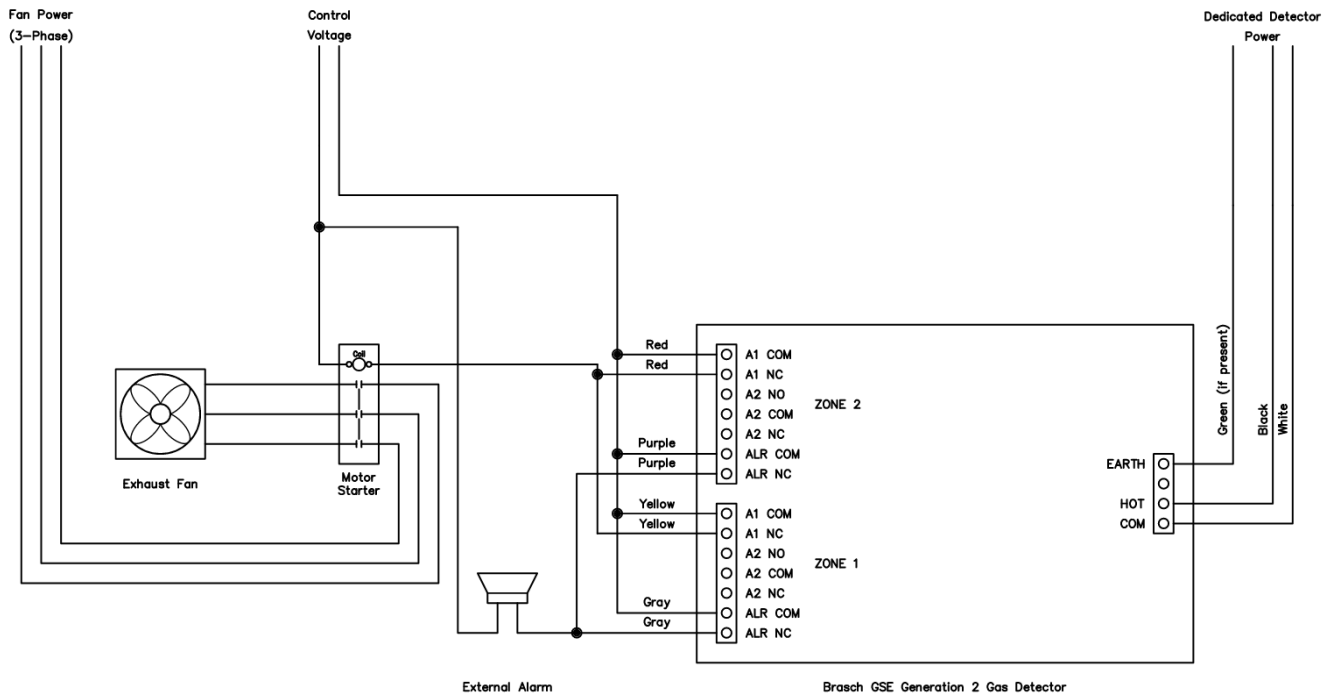

Figure 3: Wiring - Single Fan Ventilation System with Two Zones

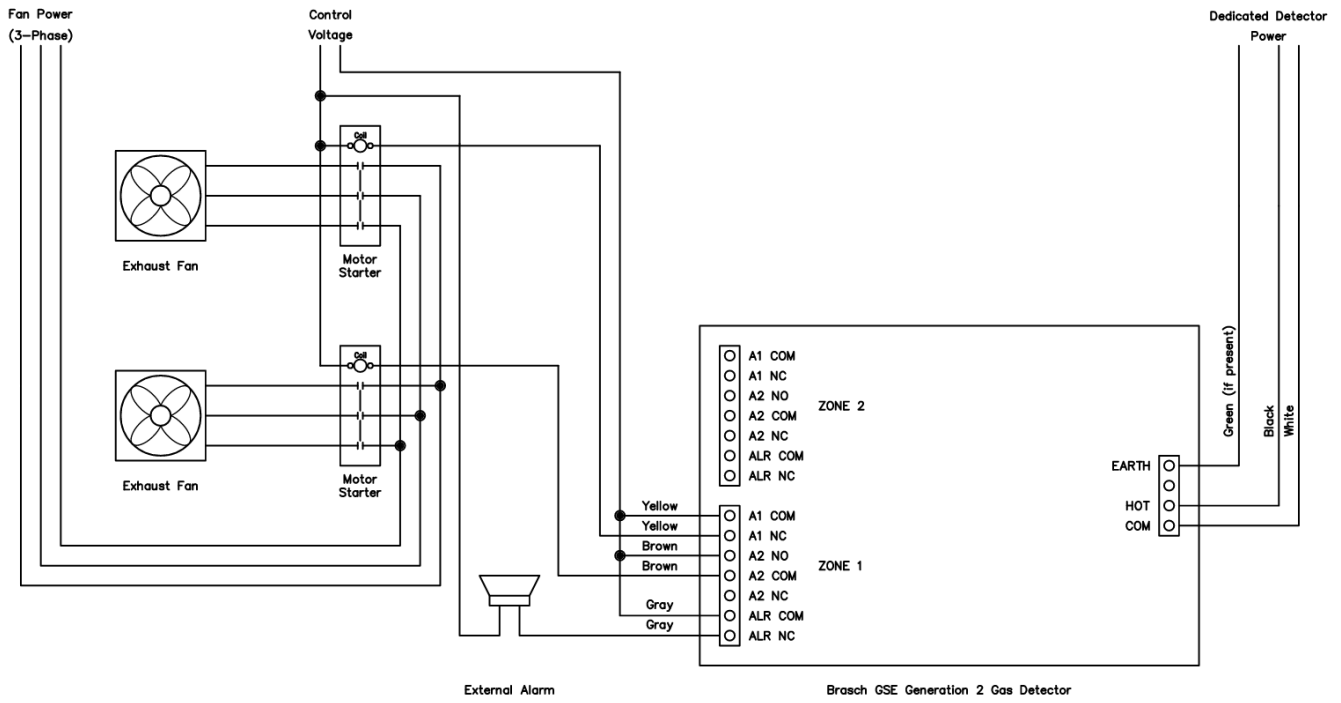

Figure 4: Wiring - Two Fan Ventilation System with One Zone

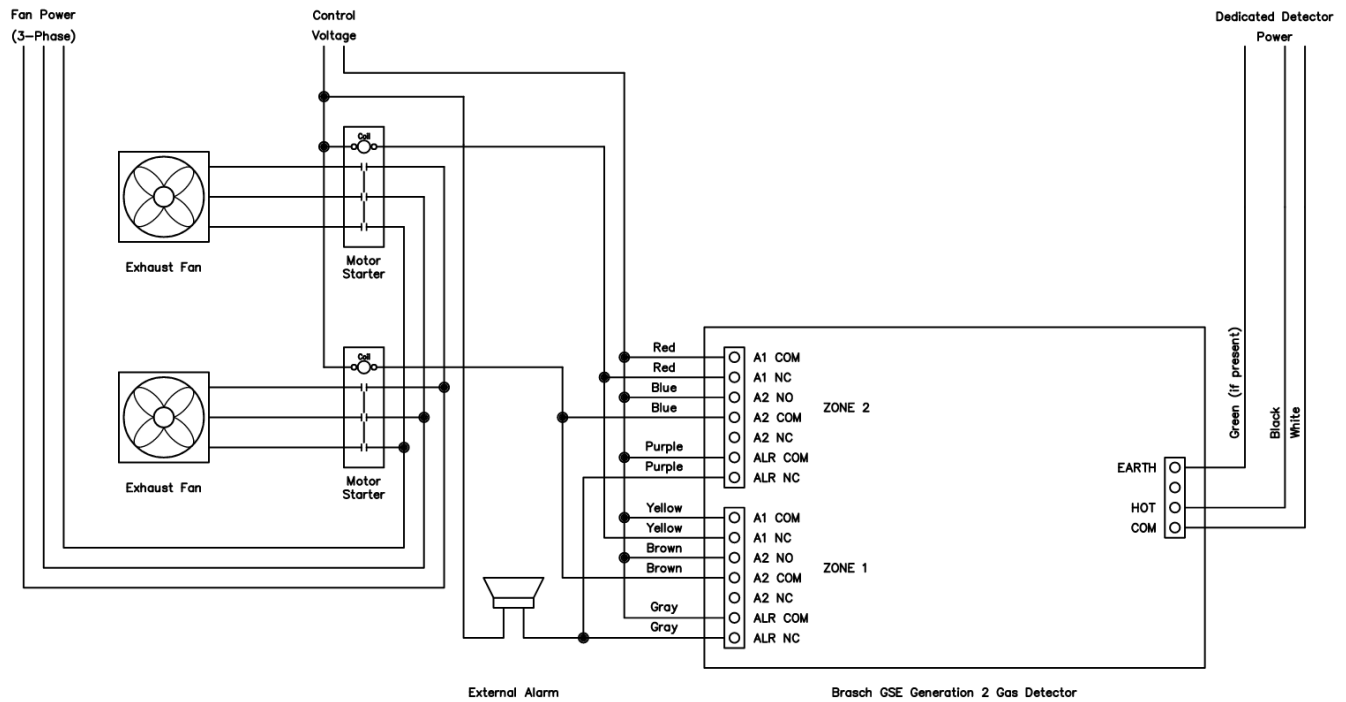

Figure 5: Wiring - Two Fan Ventilation System with Two Zones



BRASCH
ENVIRONMENTAL TECHNOLOGIES

140 Long Road, Suite 101
Chesterfield, Missouri 63005

General Contact Information

Phone: 314-291-0440
Fax: 314-291-0646
Email: customerservice@braschenvtech.com
Website: www.braschenvtech.com

Technical Support Contact Information

Phone: 314-291-0440 Option 2
Fax: 314-291-0646
Email: support@braschenvtech.com
Website: www.braschenvtech.com/support-for-existing-systems

Revision: 2.0
Issue Date: July 30, 2024
Document Number: SG02
© Brasch Environmental Technologies, LLC
All Rights Reserved

SG02
Rev 2.0 – July 30, 2024