



BRASCH
ENVIRONMENTAL TECHNOLOGIES

Submittal Form

TRNS Generation 2

BMS Transmitters



Comprehensive Monitoring

- Detects CO and/or NO₂

Greater Coverage

- Monitors up to 9,000 sq. ft.

Enhanced Durability

- Rainproof Water Resistance
- Simple Service and Maintenance

Simplified Installation

- Preconfigured Wiring
- Factory Calibration
- Customized Programming

Versatile Communication

- Analog Output via User-Selectable Current or Voltage Loop
- Digital Output via Modbus RTU Communication Protocol

Effortless Upgrade

- Works with New and Existing Building Controls Systems
- Fully Backwards Compatible with TRNS Generation 1

Technical Specifications

Input Power (Single)	24 VAC, 50/60 Hz, 0.1 A
Input Power (Dual)	24 VAC, 50/60 Hz, 0.2 A
Installation Category	II (local level, over-voltage transients less than 500V)
Storage Temperature	-50°C to 120°C (-58°F to 248°F)
Operating Temperature	-20°C to 50°C (-4°F to 122°F)
Humidity	10% to 90% (non-condensing)
Ventilation Control Relays	None
Internal Alarm	None
Front Panel Indicators	Power (green LED) Fault (yellow LED)
Display	None
Selectable Fan Settings	None
Alert Levels	None
Delay Times	None
Dimensions (Single)	4.98" W x 4.98" H x 2.18" D (12.6 cm W x 12.6 cm H x 5.5 cm D)
Dimensions (Dual)	4.98" W x 9.96" H x 2.18" D (12.6 cm W x 25.2 cm H x 5.5 cm D)
Weight (Single)	1 lbs (0.5 kg)
Weight (Dual)	2 lbs (1 kg)
Housing	Gray, NEMA 3R, polycarbonate plastic
Compliance	ANSI/ISA 92.00.01-2010 (R2015) EN 50270 FCC Part 15 Subpart B RoHS

Target Gas Specifications

Carbon Monoxide

Full Scale Span:	200 PPM
Resolution:	1 PPM
Minimum Accuracy*:	± 10% or 6 PPM
Expected Lifespan	10 years
Recommended Recalibration Time	2 years

Nitrogen Dioxide

Full Scale Span:	10 PPM
Resolution:	0.1 PPM
Minimum Accuracy*:	± 15% or 0.8 PPM
Expected Lifespan	10 years
Recommended Recalibration Time	2 years

*Allowable tolerance for accuracy and repeatability criteria as defined in Annex A, Item 2 of ANSI/ISA 92.00.01-2010 (R2015)

Mounting Location

The ability of the transmitter to sense the target gas depends greatly upon proper selection of the mounting location. This transmitter monitors the area around it by sampling the air that passes by the sensor. Since the sensor is mounted inside a housing, air must diffuse through the intake vent and pass by the sensor on its way out the exhaust vent. Therefore, the transmitter should be positioned where it can sample air that contains a target gas concentration representative of the average value in that area.

- When determining the mounting location, give special consideration to the following guidelines.
- Use one sensor per target gas for each area to be covered.
- Always prioritize locations with the highest occupation density.
- The types of gases each unit is designed to monitor have densities approximately equal to that of air. For maximum safety, mount the unit at the average breathing height – approximately 5 to 7 feet from the floor.
- Avoid mounting locations that would not be representative of the average gas value in that area. These include but are not limited to locations near doorways, fans, ventilation inlets and outlets, and areas with air velocities in excess of 3.3 ft/s (1 m/s).
- Avoid locations that would allow direct contact with water. Mounting the unit near outside garage doors may allow rain to hit the unit when the door is open.
- Avoid locations that are directly in the outlet air vents of heaters or air conditioners.
- Avoid mounting locations with normal ambient temperatures below -4°F (-20°C) or above 122°F (50°C).
- Do not allow exhaust from engines to flow directly on the unit. Each unit is designed to sense gas concentrations that are 300 to 1000 times less concentrated than the gas levels found in engine exhaust. Also, engine exhaust contains high levels of other components. These components can shorten the useful life of the sensor if they contact the sensor before being diluted by the room air volume.
- Avoid mounting locations where the unit may be hit by passing vehicles. If the unit must be mounted in these locations, provide a shielding cage around the unit for protection.
- Do not restrict the air flow to the unit housing.
- Do not mount the unit in a corner.
- Do not mount the unit near containers of chemicals such as gasoline, kerosene, alcohol, or other cleaning fluids. High level concentrations of these chemicals may be mistaken as the target gas by the sensor and cause false readings. Also, some welding gases may cause false readings.

Typical Wiring Diagrams for Ventilation Systems

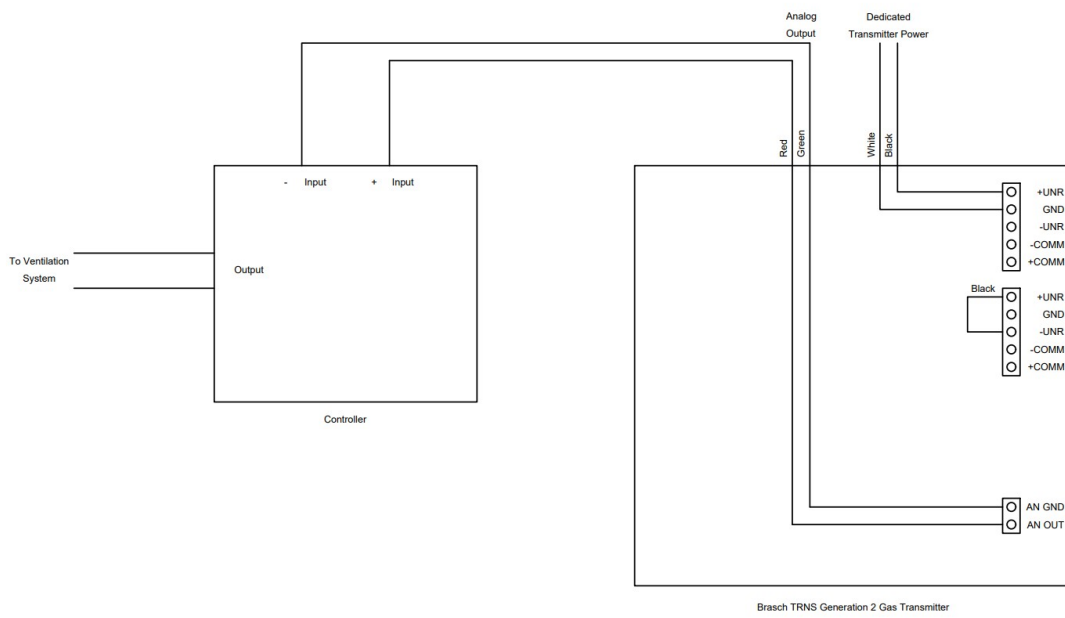

Figure 1: Wiring – Analog Output Configuration

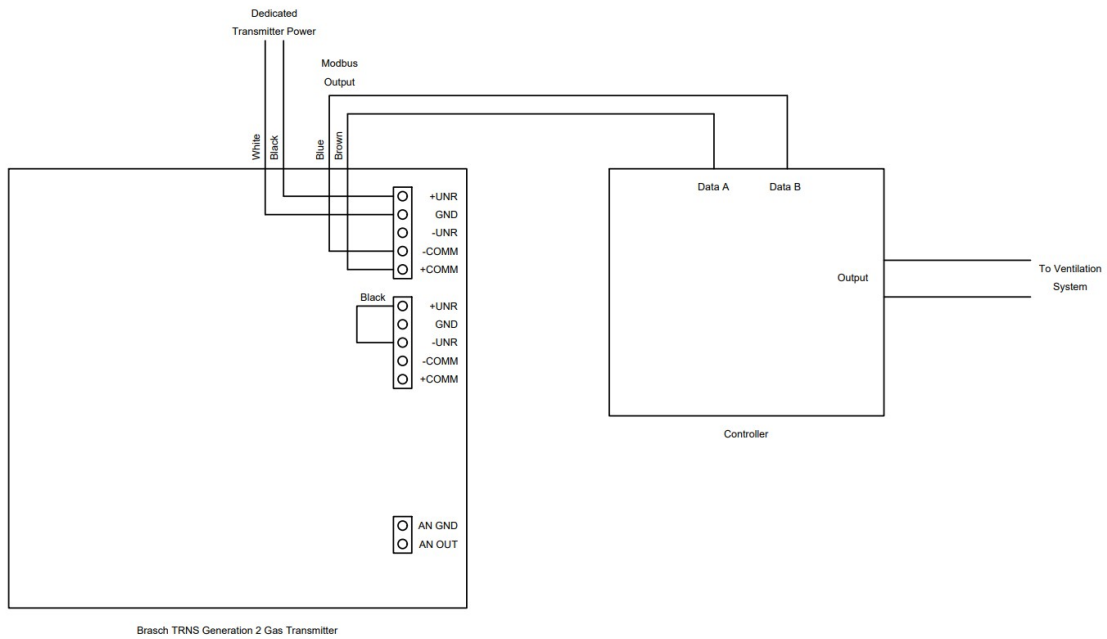

Figure 2: Wiring – Digital Output Configuration

Typical Wiring Diagrams for Ventilation Systems

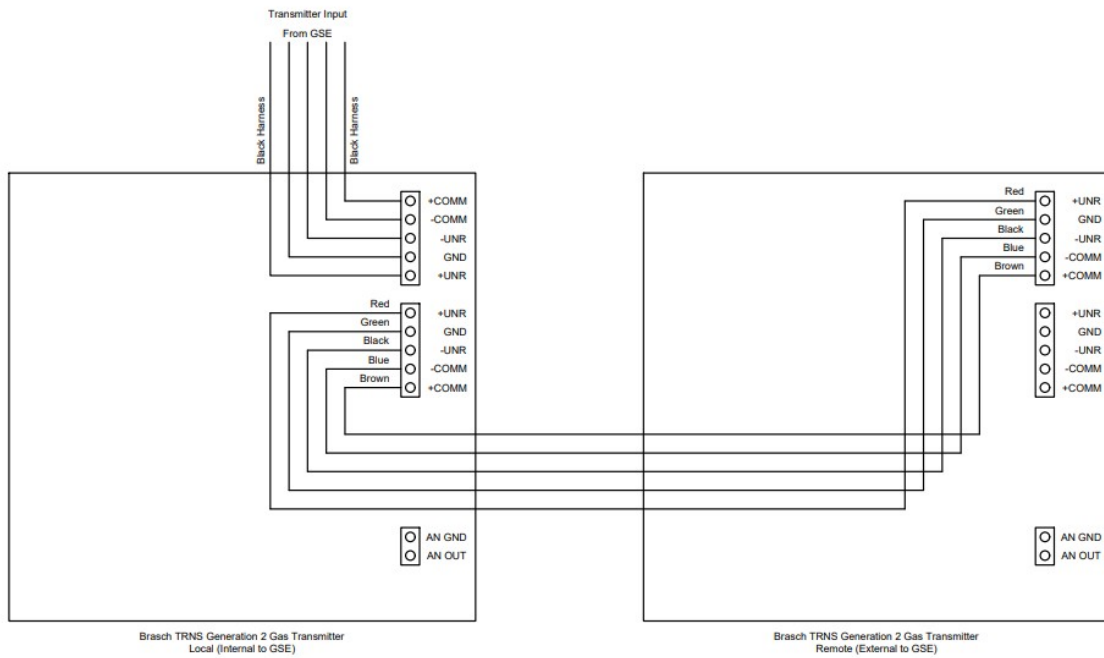

Figure 3: Wiring – Remote Sensor Configuration

Warranty Statement

Brasch Environmental Technologies, LLC warrants gas transmitters, gas detectors, control panels, and accessories for a period of two years from the date of shipment against defects in material or workmanship. Should any evidence of defects in material or workmanship occur during the warranty period, Brasch Environmental Technologies will repair or replace the affected product, at its own discretion, without charge. The company shall not be held responsible for any charges incurred with removal or replacement of allegedly defective equipment, nor for incidental or consequential damages. If any equipment has not been installed per Brasch instructions, this warranty is void. The cost to repair, replace, or service any component is not the responsibility of Brasch. Any replacement parts or service necessary must be paid in full prior to shipment or performance.



BRASCH
ENVIRONMENTAL TECHNOLOGIES

140 Long Road, Suite 101
Chesterfield, Missouri 63005

General Contact Information

Phone: 314-291-0440
Fax: 314-291-0646
Email: customerservice@braschenvtech.com
Website: www.braschenvtech.com

Technical Support Contact Information

Phone: 314-291-0440 ext. 1006
Fax: 314-291-0646
Email: customerservice@braschenvtech.com
Website: www.braschenvtech.com/support-for-existing-systems

Revision: 1.5
Issue Date: June 22, 2022
Document Number: SF10
© Brasch Environmental Technologies, LLC
All Rights Reserved