



BRASCH
ENVIRONMENTAL TECHNOLOGIES

Submittal Form

GSE-OX



Key Features

- Microprocessor Controlled
- Electrochemical Sensor
- Factory Calibrated
- Static Discharge Protection
- Power Loss Fail-Safe
- Low and High Alert Levels
- Temperature and Humidity Compensation
- Selectable Low Level Setpoint
- Adjustable Alert Time Delay
- 4-20 mA, 0-1 VDC, 0-5 VDC, or 0-10 VDC Output
- ETL Listed

SUBMITTAL FORM

GSE-OX Standalone Detector

GSE-OX Standalone Detector Specifications

Electrical

Power requirements		
Voltage	24 VAC	120 VAC
Frequency	50/60 Hz	50/60 Hz
Current Draw	0.500 A	0.125 A
Installation category	II (Local level, over-voltage transients below 500 volts.)	

Environmental

Temperature	
Operating	-15° C to 40° C, (5° F to 104° F)
Storage	-50° C to 120° C, (-58° F to 248° F)
Humidity	
Operating	10% to 90%, (non-condensing)
Storage	10% to 90%, (non-condensing)

General

Size	9.44 in. W. x 6.29 in. H. x 3.54 in. D. 24 cm. W. x 16 cm. H. x 9 cm. D.
Weight	3 lbs. (1.4 kgs)
Housing	Gray, NEMA 1, polycarbonate plastic

Recognition

Agency	ETL listed to U.L. Standard 61010B-1 and Canadian CSA C22.2, NO 1010.1
--------	---

System, Electrical

Front Panel Indicators	Power (green LED) Low alert relay (red LED) High alert relay (red LED) Alarm (red LED) Sensor active (yellow LED) Concentration (four digit LCD)	
Selectable Fan Settings	2-speed motor fans 2 individual fans	
Alert Levels	7 field selectable choices	
Delay Times	0 to 7 minutes, both entrance and exit	
Internal Alarm	106 dB @ 3.7 KHz. piezoelectric element	
Ventilation Control Relays		
Voltage	24 VAC	125 VAC
Frequency	50/60 Hz.	50/60 Hz.
Inductive power	24 VA inductive	250 VA inductive

SUBMITTAL FORM

GSE-OX Standalone Detector

Sensor Specifications

Sensors

Accuracy	Sensors shall be accurate to within +/- 5% of the full scale value.	
	GSE-CM-	+/- 10 PPM carbon monoxide
	GSE-ND-	+/- 0.5 PPM nitrogen dioxide
	GSE-OX-	+/- 0.1% oxygen
Expected Calibration Lifetime	GSE-ND-	2 years or greater*
	GSE-CM-	2 years or greater*
	GSE-OX-	3 years or greater*

*calibration lifetimes will vary according to total exposure to target gas.

Target Gas Settings

Carbon Monoxide

Full Scale Span:	200 PPM
Low Alert Settings:	
Switch Position	0 1 2 3 4 5 6 7
PPM CO	20 25 30 35 40 45 50 55
High Alert Settings:	100 PPM

Nitrogen Dioxide

Full Scale Span:	10.0 PPM
Low Alert Settings:	
Switch Position	0 1 2 3 4 5 6 7
PPM Nitrogen Dioxide	0.3 0.5 1.0 1.5 2.0 2.5 3.0 4.0
High Alert Settings:	5.0 PPM

Oxygen

Full Scale Span:	25.0 %
Low Alert Settings:	
Switch Position	0 1 2 3 4 5 6 7
% Oxygen	20.5 20.0 19.5 19.0 18.5 18.0 17.5 17.0
High Alert Settings:	16.0 %

SUBMITTAL FORM

GSE-OX Standalone Detector

Mounting Location

The ability of the unit to efficiently sense the target gas depends greatly upon proper selection of the mounting location. This unit monitors the area around it by sampling the air that passes by the sensor. Therefore, the unit should be positioned where it can sample air that contains a target gas concentration representative of the average value in that area.

When determining the mounting location, give special consideration to the following guidelines.

- Use one sensor for each 7000 to 9000 square feet of area to be monitored.
- If using remote sensors, do not locate any farther than 1000 feet from the main unit.
- The types of gases the unit is designed to monitor have densities approximately equal to that of air. For maximum safety, mount the unit at the average breathing height.
- Avoid mounting locations that would not be representative of the average gas value in that area. Locations near doorways, fans, ventilation inlets and outlets and areas with high volume of air flow should be avoided.
- Avoid locations that would allow direct contact with water. Mounting the unit near outside garage doors may allow rain to hit the unit when the door is open.
- Avoid locations that are directly in the outlet air vents of heaters or air conditioners.
- Do not allow exhaust from engines to flow directly on the unit. This unit is designed to sense gas concentrations that are 300 to 1000 times less concentrated than the gas levels found in engine exhaust. Also, engine exhaust contains high levels of other components. These components can shorten the useful life of the sensor if they contact the sensor before being diluted by the room air volume.
- Avoid mounting locations where the unit may be hit by passing vehicles. If the unit must be mounted in these locations, provide a shielding cage around the unit for protection.
- Do not restrict the air flow to the unit housing.
- Do not mount the unit near containers of chemicals such as gasoline, kerosene, alcohol or other cleaning fluids. High level concentrations of these chemicals may be mistaken as the target gas by the sensor and cause false readings. Also, some welding gases may cause false readings.

SUBMITTAL FORM

GSE-OX Standalone Detector

Typical Wiring Diagrams for Ventilation Systems

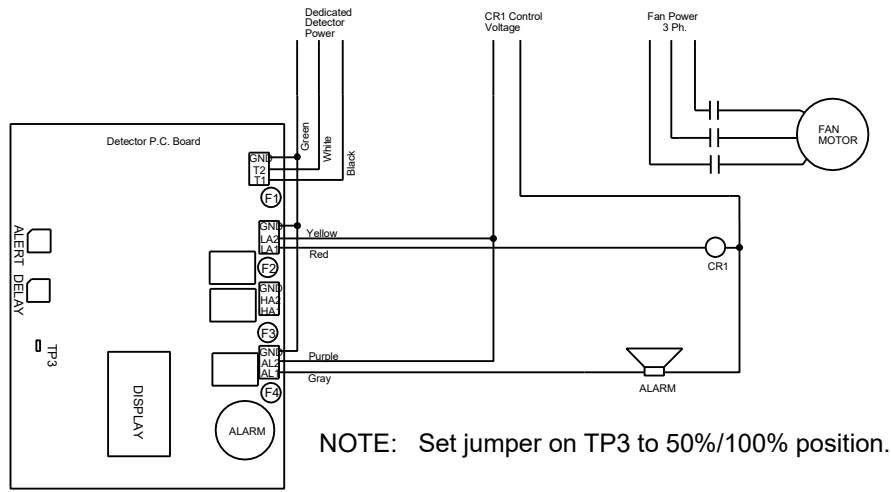

Fig. 1: Typical wiring for single fan ventilation system.

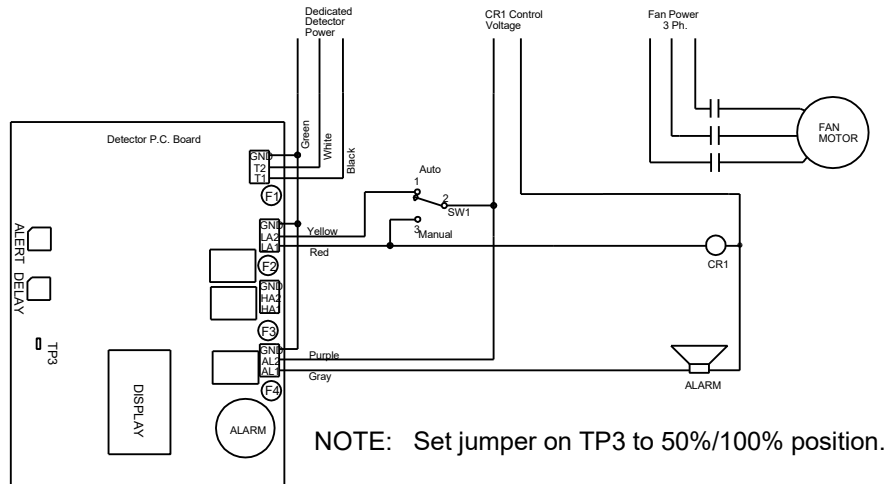

Fig. 2: Typical wiring for single fan ventilation system with auto/manual switch.

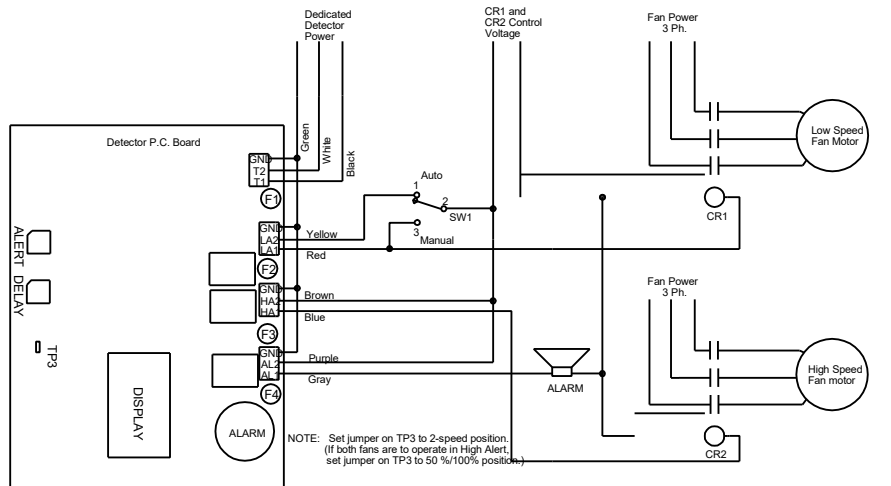

Fig. 3: Typical wiring for two fan ventilation system with auto/manual switch.